

OPERATION MAINTENANCE SERVICE MANUAL

600-8,000 LBS. AXLE CAPACITY



Introduction

This manual is designed to provide information for you to understand, use, maintain, and service your trailer running gear system. Your axles are manufactured by Dexter. Since 1960, Dexter's experience in the design, testing, and manufacturing of trailer axles has resulted in the most complete product line in the industry. The Dexter running gear system consists of axles, suspensions, and braking systems which are engineered to provide you the finest towing and stopping performance available today.

Two Dexter philosophies are at work to provide you the best product available and have enabled us to maintain our position of leadership. First, we operate on the theory that "there is always a better way" for a product to operate, to be manufactured, and/or to be serviced. We are constantly striving to find that better way.

Secondly, we maintain the highest quality control standards in the industry and adhere to ISO 9001:2015. Dexter has operated with detailed documented processes and procedures long before completing ISO Certification, continually placing quality and customer service as the focus. This ensures that critical components including axle beams, hubs, drums, spindles, and braking systems are manufactured to the highest quality standards so that we can provide our customers with dependable products, the most comprehensive product offering and reliable, consistent customer service.

Trusting is hard. Knowing who to trust even harder. Through vertical integration we engineer, design, manufacture and test virtually every part in-house to ensure superior quality trailer running gear. We fuss over details, so you don't have to. Trust Dexter.

Visit us online at www.dexteraxle.com.

Introduction

Important Safety Notice.....	4
Getting Started - Setup and Adjustment.....	4

Braking Systems - Electric

Electric Brakes.....	5
Features.....	6
Parking Brake Option.....	6
Self Adjusting Feature.....	6
Brake Controllers.....	7
Typical Trailer Wiring.....	10
How to Use Your Electric Brakes Properly.....	11
Trailer Wire Size Chart.....	11
Synchronizing Your Trailer Brakes.....	12
General Maintenance Electric Brakes.....	13
Brake Adjustment.....	13
Brake Cleaning and Inspection.....	14
Brake Lubrication.....	14
Magnets.....	15
Shoes and Linings.....	16
Introduction to Troubleshooting.....	17
Troubleshooting.....	17
Troubleshooting Chart - Electric.....	18
How to Measure Voltage.....	20
How to Measure Amperage.....	20
Magnet Amperes Chart.....	21

Braking Systems - Hydraulic

Hydraulic Brakes.....	23
Hydraulic Drum Brake Operation.....	24
Duo-Servo.....	24
Uni-Servo.....	24
Self-Adjusting Mechanism for 12 1/4" Brakes.....	25
Hydraulic Parking Brake Option.....	25
Hydraulic Disc Brakes.....	27
Actuation Systems.....	28
Electrical Schematic.....	28
Troubleshooting Guide.....	29
General Maintenance - Hydraulic Brakes.....	31
Drum Brake Adjustment - Manual.....	31
Wheel Cylinders.....	32
Brake Lines.....	32
Shoes and Linings.....	32
Hardware.....	33
Instructions for Brake Caliper Kit - 3.5K Disc Brakes.....	33
Instructions for Brake Rotor Kit - 3.5K Disc Brakes.....	34
Instructions for Brake Rotor Kit - 6K or 8K Disc Brakes.....	36
Instructions for Brake Hub/Rotor Kit - 7K Disc Brakes.....	37
Instructions for Brake Pad Kit - 6K, 7K or 8K Disc Brakes.....	39
Instructions for Brake Caliper Kit - 6K, 7K or 8K Disc Brakes.....	42
Introduction to Troubleshooting.....	45
Troubleshooting Chart - Hydraulic.....	46

Hubs/Drums/Bearings

Hubs/Drums/Bearings.....	48
Hub Removal - Standard Bearings.....	49
Brake Drum Inspection.....	49
Bearing Inspection.....	50
Bearing Lubrication - Grease.....	52

Bearing Lubrication - Oil.....	52
Recommended Wheel Bearing Lubrication Specifications	53
Seal Inspection and Replacement.....	55
Bearing Adjustment and Hub Replacement.....	56
Typical E-Z Lube® After Spring 2002.....	57
E-Z Lube® Lubrication	57
Nev-R-Lube® Drums/Bearings	59
Drum Removal	60
Bearing Inspection	60
Nev-R-Lube® Bearing End Play Inspection	61
Bearing Replacement and Drum Installation.....	62
Axle Installation	
Axle & Suspension Installation	64
Suspensions	
Suspension Systems	65
Double Eye Leaf Springs.....	65
Grease Lubricated Suspension Bushings	66
Slipper Leaf Springs	66
Inspection and Replacement.....	67
Suspension Fastener Torque Values	67
Torflex® Suspension	69
Airflex® Suspension	70
Wheels and Tires	
Wheels	72
Wheel Selection	72
Torque Requirements.....	73
Wheel Torque Requirements	74
Maximum Wheel Fastener Torque.....	75
Tires	76
Tire Wear Diagnostic Chart.....	77
Replacement Parts/Kits	
Magnet Replacement Kits and Brake Nut Torque.....	78
Seal Replacement Reference	78
Brake Shoe Replacement Kits	79
Bearing Replacement Chart.....	80
Storage	
Storage Preparation.....	81
After Prolonged Storage - Inspection Procedures.....	82
Trip Preparation Checklist.....	83
Maintenance Schedule	
Maintenance Schedule Chart.....	84
Warranty	
Limited Warranty.....	85
Axle Identification	
Axle Identification	88
Video Gallery	
Dexter Video Gallery	90

Important Safety Notice

Appropriate service methods and repair procedures are essential for the safe, reliable operation of all running gear as well as the personal safety of the individual doing the work. This manual provides general directions for performing service and repair work with tested, effective techniques. Following these guidelines will help assure reliability.

There are numerous variations in procedures, techniques, tools, parts for servicing axles, as well as in the skill of the individual doing the work. This manual cannot possibly anticipate all such variations and provide advice or cautions as to each. Anyone who departs from the instructions provided in this manual must first establish that they neither compromise their personal safety nor the vehicle integrity by their choice of methods, tools, or parts.

Refer to your vehicle manufacturer's owners manual for additional procedures, techniques, and warnings prior to performing any maintenance or repairs.



CAUTION

This is the safety alert symbol. It is used to alert you to potential injury hazards. Obey all safety messages that follow this symbol to avoid possible injury or death.

Getting Started - Setup and Adjustment

For proper performance, all new axles should have the following checked at the specified intervals:

- **Wheel Nut Torque:** at 10, 25, and 50 miles
- **Brake Adjustment:** at 200 and 3,000 miles
- **Tire pressure:** to manufacturer's requirements
- **Brake synchronization:** set brake controller per controller manufacturer's directions

Electric Brakes

The electric brakes on your trailer are similar to the drum brakes on your automobile. The basic difference is that your automotive brakes are actuated by hydraulic pressure while your electric trailer brakes are actuated by an electromagnet. With all of the brake components connected into the system, the brake will operate as follows:

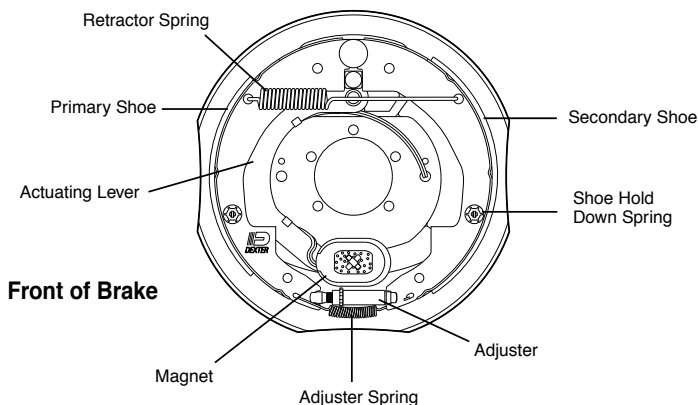

When the electrical current is fed into the system by the controller, it flows through the electromagnets in the brakes. The high capacity electromagnets are energized and are attracted to the rotating armature surface of the drums which moves the actuating levers in the direction that the drums are turning.

The resulting force causes the actuating cam block at the shoe end of the lever to push the primary shoe out against the inside surface of the brake drum. The force generated by the primary shoe acting through the adjuster moves the secondary shoe out into contact with the brake drum.

Increasing the current flow to the electromagnet causes the magnet to grip the armature surface of the brake drum more firmly. This results in increasing the pressure against the shoes and brake drums until the desired stop is accomplished.

Features

Electrically actuated brakes have several advantages over other brake actuation systems.

1. They can be manually adjusted at the controller to provide the correct braking capability for varying road and load conditions.
2. They can be modulated to provide more or less braking force, thus easing the brake load on the towing vehicle.
3. They have very little lag time from the moment the tow vehicle's brakes are actuated until the trailer brakes are actuated.
4. In an emergency situation, they can provide some braking independent of the tow vehicle.

Parking Brake Option

(Not available on all sizes)

Dexter electric brakes with parking brake option are mechanically operated by a cable. Cable force applied to the parking lever creates a torque through the pivot pin and cam assembly. Torque transferred to the parking cam results in a spreading force between the primary and secondary shoes. The shoes, in turn, move towards the drum until contact is made. Friction generated between the drum and lining contact surface keeps the drum from rotating under normal loading conditions.

Self Adjusting Feature

(Not available on all sizes)

Dexter electric brakes may be equipped with a forward self-adjust feature. This will allow the brakes to adjust on both forward and reverse stops. Brake adjustment occurs when lining wear results in enough gap between the shoes and the brake drum surface. This added clearance will allow the adjuster mechanism to rotate the screw assembly at the bottom of the brake. That action expands the distance between the shoes and thus closes the gap to the drum surface.

Brake Controllers

Electric brake controllers provide power to the magnets to actuate the trailer brakes. Dexter offers a state-of-the-art inertial controller called the Predator DX2[®]. This controller features a patented accelerometer design which senses the deceleration of the towing vehicle and sends a proportional voltage to the electric trailer brakes. Other features include a visual gain setting for quick and easy adjustment and a digital LED display to show the voltage output. A manual override sends full voltage to the trailer brakes, regardless of gain setting, for emergency conditions and also illuminates the brake lights to warn of an impending stop.

Most electric brake controllers provide a modulation function that varies the current to the electric brakes with the pressure on the brake pedal or amount of deceleration of the tow vehicle. Electronic or timing controllers do not provide proportional modulation. These controllers tend to be inexpensive but not the best choice for optimum braking. It is important that your brake controller provide approximately 2 volts to the braking system when the brake pedal is first depressed and gradually increases the voltage to 12 volts as brake pedal pressure is increased. If the controller “jumps” immediately to a high voltage output, even during a gradual stop, then the electric brakes will always be fully energized and will result in harsh brakes and potential wheel lockup.

Dexter Electric Brakes

Wired in parallel.

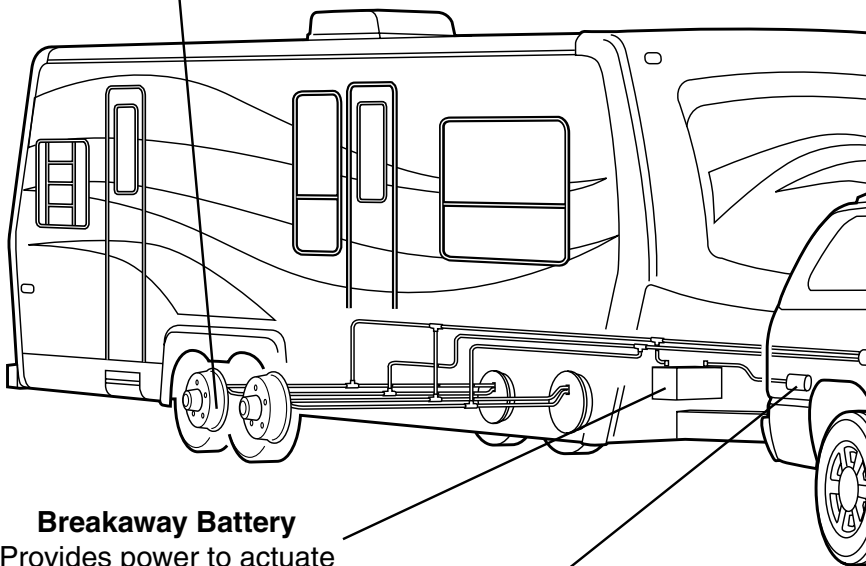

Breakaway Battery

Provides power to actuate trailer brakes in the event of trailer breakaway.

Breakaway Switch

Switches battery power to brakes if breakaway occurs.

Controller

Electric brake controller provides power to the magnets to actuate the trailer brakes.

Battery

Connect controller directly.

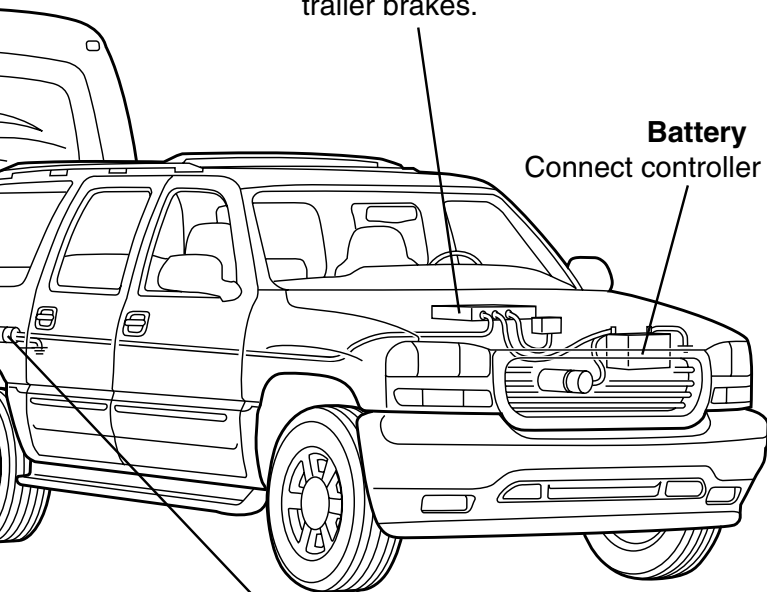

Connector

Used to connect and disconnect trailer and tow vehicle.
(Always ground trailer brakes through connector).

Typical Trailer Wiring

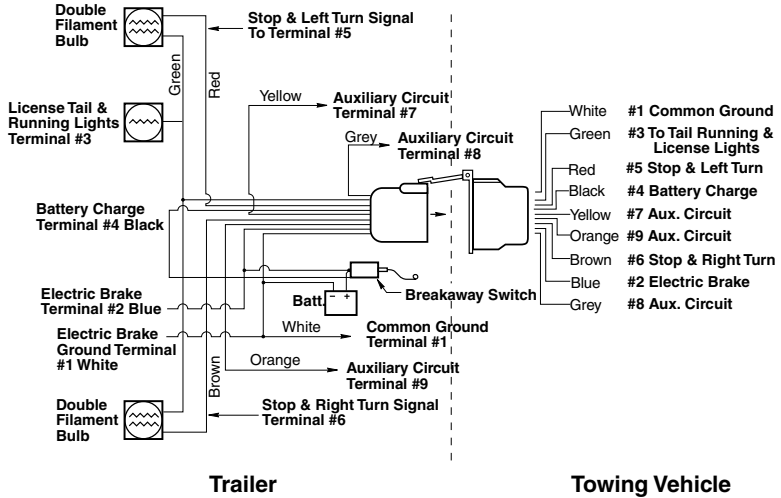

7-Circuit Receptacle

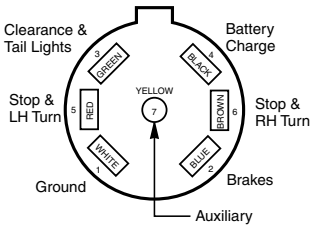

9-Circuit Receptacle

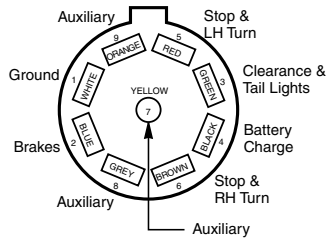

View Looking into Tow Vehicle Receptacle

How to Use Your Electric Brakes Properly

Your trailer brakes are designed to work in synchronization with your tow vehicle brakes. Never use your tow vehicle or trailer brakes alone to stop the combined load.

Your brake controller must be set up according to the manufacturer's recommendations to ensure proper synchronization between the tow vehicle and the trailer. Additionally, you may have to make small adjustments occasionally to accommodate changing loads and driving conditions.

Proper synchronization of tow vehicle to trailer braking can only be accomplished by road testing. Brake lockup, grabbiness, or harshness is quite often due to the lack of synchronization between the tow vehicle and the trailer being towed, too high of a threshold voltage (over 2 volts), or under adjusted brakes.

Before any synchronization adjustments are made, your trailer brakes should be burnished-in by applying the brakes 20-30 times with approximately a 20 m.p.h. decrease in speed, e.g. 40 m.p.h. to 20 m.p.h. Allow ample time for brakes to cool between application. This allows the brake shoes and magnets to slightly "wear-in" to the drum surfaces.

Trailer Wire Size Chart

Number of Brakes	Hitch-to-Axle Distance in Feet	Recommended Minimum Hookup Wire Size (Copper)
2		12 AWG
4	Under 30	12 AWG
4	30-50	10 AWG
6	Under 30	10 AWG
6	30-50	8 AWG

Synchronizing Your Trailer Brakes

To ensure safe brake performance and synchronization, read the brake controller manufacturer's instructions completely before attempting any synchronization procedure.



CAUTION

Before road testing, make sure the area is clear of vehicular and pedestrian traffic. Failure to brake safely could result in an accident and personal injury to yourself and/or others.

Make several hard stops from 20 m.p.h. on a dry paved road free of sand and gravel. If the trailer brakes lock and slide, decrease the gain setting on the controller. If they do not slide, slightly increase the gain setting. Adjust the controller just to the point of impending brake lockup and wheel skid.

Note: Not all trailer brakes are capable of wheel lockup. Loading conditions, brake type, wheel and tire size can all affect whether a brake can lock. It is not generally considered desirable to lock up the brakes and slide the tires. This can cause unwanted flat spotting of the tires and could also result in a loss of control.

If the controller is applying the trailer brakes before the tow vehicle brakes, then the controller adjustments should be made so the trailer brakes come on in synchronization with the tow vehicle brakes. For proper braking performance, it is recommended that the controller be adjusted to allow the trailer brakes to come on just slightly ahead of the tow vehicle brakes. When proper synchronization is achieved there will be no sensation of the trailer "jerking" or "pushing" the tow vehicle during braking.

General Maintenance - Electric Brakes

Brake Adjustment

Dexter electric brakes that have a self adjusting feature require no manual adjustment. Brakes not equipped with this feature can be adjusted by using the following procedure:

Brakes should be adjusted (1) after the first 200 miles of operation when the brake shoes and drums have “seated,” (2) at 3,000 mile intervals, (3) or as use and performance requires. The brakes should be adjusted in the following manner:

1. Jack up trailer and secure on adequate capacity jack stands. Follow trailer manufacturer’s recommendations for lifting and supporting the unit. Make sure the wheel and drum rotates freely.



CAUTION

Do not lift or support the trailer on any part of the axle or suspension system. Never go under any trailer unless it is properly supported on jack stands which have been rated for the load. Improperly supported vehicles can fall unexpectedly and cause serious injury or death.

2. If equipped, remove the adjusting hole cover, if present, from the adjusting slot on the bottom of the brake backing plate.
3. With a screwdriver or standard adjusting tool, rotate the star wheel of the adjuster assembly to expand the brake shoes. Adjust the brake shoes out until the pressure of the linings against the drum makes the wheel very difficult to turn.

Note: For drop spindle axles, a modified adjusting tool may be necessary.

4. Then rotate the star wheel in the opposite direction until the wheel turns freely with a slight lining drag.
5. Replace the adjusting hole cover, if available, and lower the wheel to the ground.
6. Repeat the above procedure on all brakes. For best results, the brakes should all be set at the same clearance.

Brake Cleaning and Inspection

Your trailer brakes must be inspected and serviced immediately if a loss of performance is indicated. With normal use, servicing at one year intervals is usually adequate. With increased usage, this work should be done more frequently as required. Magnets and shoes must be changed when they become excessively worn or scored, a condition which can reduce vehicle braking.

Clean the backing plate, magnet arm, magnet, and brake shoes. Make certain that all the parts removed are replaced in the same brake and drum assembly. Inspect for any loose or worn parts, stretched or deformed springs and replace as necessary.



CAUTION

POTENTIAL ASBESTOS DUST HAZARD!

Some older brake linings may contain asbestos dust, which has been linked to serious or fatal illnesses. Certain precautions need to be taken when servicing brakes:

- 1. Avoid creating or breathing dust.**
- 2. Avoid machining, filing or grinding the brake linings.**
- 3. Do not use compressed air or dry brushing for cleaning (dust can be removed with a damp brush).**

Brake Lubrication

Before reassembling, apply a light film of grease or anti-seize compound on the brake anchor pin, the actuating arm bushing and pin, and the areas on the backing plate that are in contact with the brake shoes and magnet lever arm. Apply a light film of grease on the actuating block mounted on the actuating arm.

CAUTION

Do not get grease or oil on the brake linings, drums or magnets.

Magnets

Your electric brakes are equipped with high quality electromagnets that are designed to provide the proper input force and friction characteristics. Your magnets should be inspected and replaced if worn unevenly or abnormally. As indicated below, a straightedge should be used to check magnet condition. For best results, the magnet should be flat.

Even if wear is normal as indicated by your straightedge, the magnets should be replaced if any part of the magnet coil has become visible through the friction material facing of the magnet. It is also recommended that the drum armature surface be refaced when replacing magnets (see section on Brake Drum Inspection). Magnets should also be replaced in pairs - both sides of an axle. Use only genuine Dexter replacement parts when replacing your magnets.

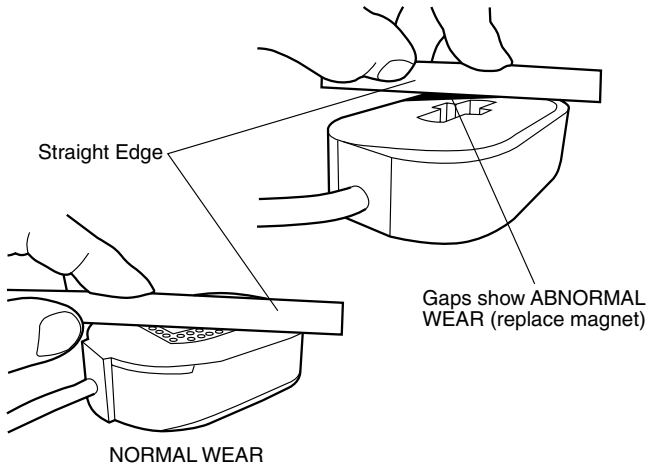

Shoes and Linings

A simple visual inspection of your brake linings will tell if they are usable. Replacement is necessary if the lining is worn to 1/16" or less. Shoes contaminated with grease or oil, or abnormally scored or gouged should also be replaced. Hairline heat cracks are normal in bonded linings and should not be cause for concern. When replacement is necessary, it is important to replace both shoes on each brake and both brakes of the same axle. This will help retain the "balance" of your brakes.

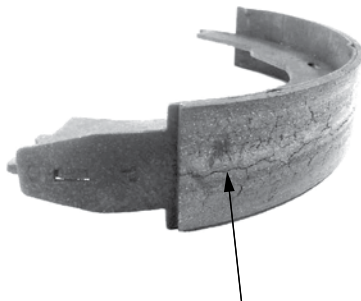

Acceptable
Hairline Cracks



CAUTION

POTENTIAL ASBESTOS DUST HAZARD!

Some older brake linings may contain asbestos dust, which has been linked to serious or fatal illnesses. Certain precautions need to be taken when servicing brakes:

1. Avoid creating or breathing dust.
2. Avoid machining, filing or grinding the brake linings.
3. Do not use compressed air or dry brushing for cleaning (dust can be removed with a damp brush).

After replacement of brake shoes and linings, the brakes must be re-burnished to seat in the new components. This should be done by applying the brakes 20 to 30 times from an initial speed of 40 m.p.h., slowing the vehicle to 20 m.p.h. Allow ample time for brakes to cool between applications. This procedure allows the brake shoes to seat in to the drum surface.

Introduction to Troubleshooting

Proper brake function is critical to the safe operation of any vehicle. If problems are encountered with your trailer braking system, the following guide can be used to find the causes and remedies for some of the more common problems. If you are unsure or unable to resolve the problem, please contact your nearest repair facility for professional assistance.

Troubleshooting

Most electric brake malfunctions that cannot be corrected by either brake adjustments or synchronization adjustments, can generally be traced to electrical system failure. Voltmeters and ammeters are essential tools for proper troubleshooting of electric brakes.

Mechanical causes are ordinarily obvious, i.e. bent or broken parts, worn out linings or magnets, seized lever arms or shoes, scored drums, loose parts, etc. Replace defective parts with genuine Dexter replacements.

Please consult the following troubleshooting charts to determine the causes and solutions for common problems found in trailer braking systems.

CAUTION

Best braking performance is achieved with a controller setting that is just short of wheel lock up or slide. Overly aggressive braking which results in wheel lock up and sliding, can cause a dangerous loss of control and result in personal injury or death.

Troubleshooting

SYMPTOM	CAUSES	REMEDIES
No Brakes	Open Circuits	Find & Correct
	Severe Underadjustment	Adjust Brakes
	Faulty Controller	Test & Correct
	Short Circuits	Find & Correct
Weak Brakes	Grease or Oil on Magnets or Linings	Clean or Replace
	Corroded Connections	Clean & Correct Cause of Corrosion
	Worn Linings or Magnets	Replace
	Scored or Grooved Brake Drums	Machine or Replace
	Improper Synchronization	Correct
	Underadjustment	Adjust Brakes
	Glazed Linings	Reburnish or Replace
	Overloaded Trailer	Correct
Locking Brakes	Underadjustment	Adjust
	Improper Synchronization	Correct
	Faulty Controller	Test & Correct
	Loose, Bent or Broken Brake Components	Replace Components
	Out-of-Round Brake Drums	Machine or Replace
	Insufficient Wheel Load	Adjust System Resistor and Synchronize
Intermittent Brakes	Faulty Controller	Test & Correct
	Broken Wires	Repair or Replace
	Loose Connections	Find & Repair
	Faulty Ground	Find & Repair

Troubleshooting

SYMPTOM	CAUSES	REMEDIES
Brakes Pull to One Side	Wrong Magnet Lead Wire Color	Correct
	Incorrect Adjustment	Adjust
	Grease or Oil on Linings or Magnets	Clean or Replace
	Broken Wires	Find & Repair
	Bad Connections	Find & Repair
Harsh Brakes	Underadjustment	Adjust
	Improper Synchronization	Correct
	Improper Controller	Change
	Faulty Controller	Test & Correct
Noisy Brake	Underadjustment	Adjust
	Lack of Lubrication	Lubricate
	Broken Brake Components	Replace Component
	Incorrect Brake Components	Correct
Surging Brakes	Grease or Oil on Linings or Magnet	Clean or Replace
	Out-of-Round or Cracked Brake Drums	Machine or Replace
	Faulty Controller	Test & Correct
Dragging Brakes	Overadjustment	Readjust
	Out-of-Round Brake Drums	Machine or Replace
	Incorrect Brake Components	Replace
	Loose, Bent or Broken Brake Components	Replace
	Faulty Breakaway Switch	Repair or Replace
	Loose Wheel Bearing Adjustment	Adjust
	Bent Spindle	Replace Axle

How to Measure Voltage

System voltage is measured at the magnets by connecting the voltmeter to the two magnet lead wires at any brake. This may be accomplished by using a pin probe inserted through the insulation of the wires. The engine of the towing vehicle should be running when checking the voltage so that a low battery will not affect the readings.

Voltage in the system should begin at 0 volts and, as the controller bar is slowly actuated, should gradually increase to about 12 volts. If the controller does not produce this voltage control, consult your controller manual.

The threshold voltage of a controller is the voltage applied to the brakes when the controller first turns on. Lower threshold voltage will provide for smoother braking. If the threshold voltage is too high, the brakes may feel grabby and harsh.

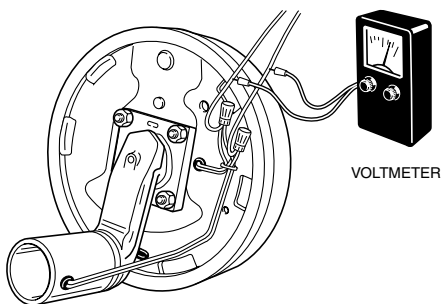

How to Measure Amperage

System amperage is the current flowing in the system when all the magnets are energized. The amperage will vary in proportion to the voltage. The engine of the tow vehicle should be running with the trailer connected when checking the trailer braking system.

One place to measure system amperage is at the BLUE wire of the controller, which is the output to the brakes. The BLUE wire must be disconnected and the ammeter put in series into the line. System amperage draw should be as noted in the following table. Make sure your ammeter has sufficient capacity and note polarity to prevent damaging your ammeter.

Magnet Amperes Chart

Brake Size	Amps/Magnet	Two Brakes	Four Brakes	Six Brakes	Magnet Ohms
7" x 1 1/4"	2.5	5.0	10.0	15.0	3.9
10" x 1 1/2"	3.0	6.0	12.0	18.0	3.2
10" x 2 1/4"	3.0	6.0	12.0	18.0	3.2
12" x 2"	3.0	6.0	12.0	18.0	3.2
12 1/4" x 2 1/2"	3.0	6.0	12.0	18.0	3.2
12 1/4" x 3 3/8"	3.0	6.0	12.0	18.0	3.2

If a resistor is used in the brake system, it must be set at zero or bypassed completely to obtain the maximum amperage reading. Individual amperage draw can be measured by inserting the ammeter in the line at the magnet you want to check. Disconnect one of the magnet lead wire connectors and attach the ammeter between the two wires. Make sure that the wires are properly reconnected and sealed after testing is completed.

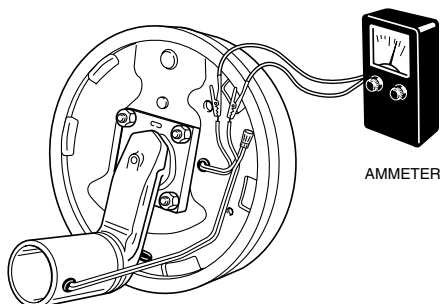

The most common electrical problem is low or no voltage and amperage at the brakes. Common causes of this condition are:

1. Poor electrical connections
2. Open circuits
3. Insufficient wire size
4. Broken wires
5. Blown fuses (fusing of brakes is not recommended)
6. Improperly functioning controllers or resistors

Another common electrical problem is shorted or partially shorted circuits (indicated by abnormally high system amperage). Possible causes are:

1. Shorted magnet coils
2. Defective controllers
3. Bare wires contacting a grounded object

Finding the cause of a short circuit in the system is done by isolating one section at a time. If the high amperage reading drops to zero by unplugging the trailer, then the short is in the trailer. If the amperage reading remains high with all the brake magnets disconnected, the short is in the trailer wiring.

All electrical troubleshooting procedures should start at the controller. Most complaints regarding brake harshness or malfunction are traceable to improperly adjusted or non-functioning controllers. See your controller manufacturer's data for proper adjustment and testing procedures. For best results, all the connection points in the brake wiring should be sealed to prevent corrosion. Loose or corroded connectors will cause an increase in resistance which reduces the voltage available for the brake magnets.

Hydraulic Brakes

Dexter offers several varieties of hydraulic trailer brakes. Your vehicle may be equipped with drum brakes or disc brakes.

The hydraulic brakes on your trailer are much like those on your automobile or light truck. The hydraulic fluid from a master cylinder or actuation system is used to actuate the wheel cylinder which, in turn, applies force against the brake shoes and drum. The main difference between automotive hydraulic brakes and hydraulic trailer brakes is the trailers' actuation system. These systems respond to the braking signal from the tow vehicle and supply the required brake fluid volume and pressure to the trailer brakes.

In the following pages you will find a more detailed description of the hydraulic brakes and actuation system used on your trailer.

CAUTION

The maximum operating pressure for Dexter brakes:

- **7" diameter drum brakes**
maximum operating pressure is 750 psi
- **10" diameter and larger drum brakes**
maximum operating pressure is 1,000 psi
- **Hydraulic disc brakes (all sizes)**
maximum operating pressure is 1,600 psi

Hydraulic Drum Brake Operation

Duo-Servo

The duo-servo brake uses a dual piston wheel cylinder to apply the brakes. This type of brake is typically used in an electric/hydraulic, vacuum/hydraulic, or air/hydraulic system. A description of operation of this brake is as follows:

When the brakes are applied, the double-acting wheel cylinder moves the primary and secondary shoes towards the drum. The frictional force between the brake drum and lining attempts to turn the primary shoe into the secondary shoe. The secondary shoe is forced onto the anchor pin and from this point, the secondary and primary shoes attempt to “wrap around”. In essence, the brake has utilized frictional force to help the applying force on both shoes.

If the brakes are applied while the vehicle is backing, the shoes rotate in the direction of the drum rotation. This causes the secondary shoe to leave the anchor and causes the primary shoe to move against the anchor. Action of the brake is the same in reverse as forward.

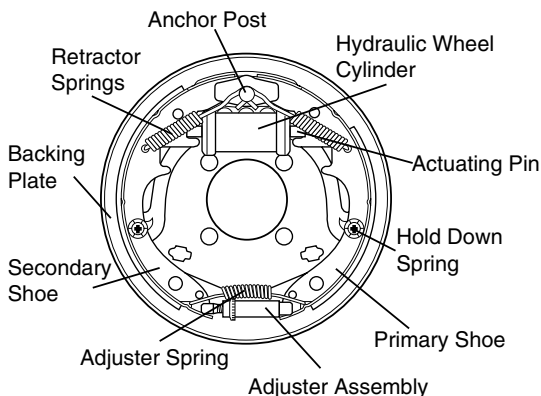

Uni-Servo

This type of hydraulic brake utilizes a single acting cylinder. Upon actuation, the primary shoe is pressed against the brake drum, which causes the shoe to move in the direction of rotation. This movement in turn actuates the secondary shoe through the adjuster assembly. Braking in reverse is significantly less effective than in the forward direction.

Another variation is called a “free backing” brake which is commonly used on trailers with a surge hitch system. When backing with a surge brake hitch, normal brakes are applied through the surge mechanism and if there is more brake force on the trailer than the tow vehicle can override, no backing is possible. The free backing brake was developed to allow backing in this application. This brake has a primary shoe on a pivot which allows normal application in the forward direction, but allows the primary shoe to rotate away from the drum surface when backing.

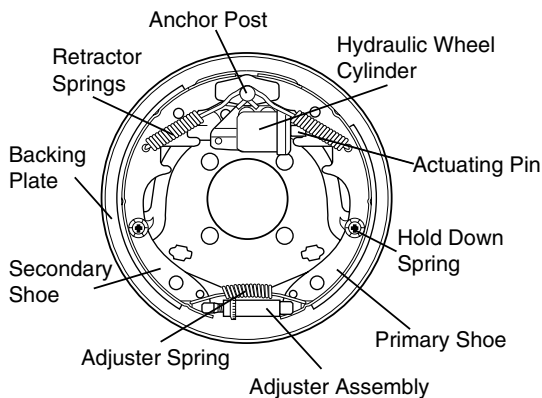

Self Adjusting Mechanism for 12¼" Hydraulic Brakes

Forward self-adjust hydraulic brakes were introduced in March of 1997. This feature adjusts the brakes on both forward and reverse stops. Brake adjustment occurs only when lining wear results in enough gap between the shoes and the drum surface. This added clearance will allow the adjuster mechanism to rotate the screw assembly at the bottom of the brake. That action expands the distance between the shoes and thus closes the gap to the drum surface.

Hydraulic Parking Brake Option (Not available on all sizes)

The parking feature on Dexter hydraulic brakes is cable operated. On the 10" and 12" brakes, the parking cable body is mounted to the brake backing plate. The cable end is attached to the internal parking brake lever to actuate the brake. On Dexter 12 1/4" brakes manufactured before February of 2002, the parking cable body mounts to a support plate which is attached to the brake mounting flange. The cable end is routed through the dust shield and the brake spider, to attach to the internal parking brake lever. For 12 1/4" brakes produced after February of 2002, a short cable is installed directly into the backing plate to provide a convenient means for the trailer manufacturer to attach an appropriate operating system.

The internal parking brake lever of 10" and 12" Dexter brakes, which is mounted to the secondary shoe, transfers applied cable force through a parking strut which is attached to the primary shoe. This transferred load generates a spreading force between the primary and secondary shoes. The shoes move toward the drum until contact is made. Friction generated between the drum and lining contact surface results in parking brake capability.

The internal parking brake lever of Dexter 12 1/4" brakes transfers the applied cable force through a cam mechanism. The cam mechanism generates a spreading force between the primary and secondary shoes. The shoes move toward the drum until contact is made. Friction generated between the drum and lining contact surface results in parking brake capability.



Hydraulic Disc Brakes

Dexter manufactures two types of disc brakes, the floating caliper and the fixed caliper brake. With both styles, the disc brake uses friction pads astride a ventilated rotor which is attached to the wheel hub. When the brake is actuated, the pads are pressed against the sides of the rotor causing drag to slow the rotating disc. This action converts the kinetic energy (motion) into heat. The heat is dissipated rapidly by the ventilated disc.

The floating caliper brake uses piston(s) situated on one side of the brake rotor. Hydraulic fluid pressure pushes against the piston(s) to apply the inboard brake pad. As the inboard pad exerts force against the rotating rotor surface, the caliper moves laterally towards the trailer frame and in turn applies an equivalent force to the outboard brake pad against the rotor surface. As the lining material wears, the caliper will automatically maintain the proper lining to rotor clearance. The floating caliper design is used on Dexter 3,500 lb., 10,000 lb. and 12,000 lb. axle models.

The fixed caliper method uses pistons situated on both sides of the rotor. During actuation, hydraulic pressure pushes against the pistons to apply the inboard and outboard brake pads equally to decelerate the rotating rotor. The caliper is fixed and stays stationary during brake actuation and brake adjustment. Brake pad to rotor clearance is maintained as lining wear occurs via the brake piston and internal caliper seal. The fixed caliper design is used on the Dexter 6,000, 7,000 and 8,000 lb. axle models.

Disc brake effectiveness is the same going either in a forward or reverse direction. All Dexter disc brakes should be actuated with a braking system that is capable of providing a maximum hydraulic pressure of 1,600 psi.



Actuation Systems

To effectively operate your hydraulic trailer brakes we recommend the Dexter electrically controlled hydraulic brake actuation device (also referred to as E/H brake actuator), controlled by the Predator DX2® electronic brake controller. These high performance hydraulic power modules will supply pressurized brake fluid to your trailer brakes in proportion to the amount of braking effort called for by the towing vehicles' deceleration rate.

CAUTION

It is the responsibility of the end user to ensure that their in-cab electronic controller is compatible with the Dexter E/H brake actuator. Dexter attempts to provide compatibility with most controllers available, but is unable to anticipate design changes that might be introduced by the various controller manufacturers.

The E/H 1000 will supply 1,000 psi for your drum brakes and the E/H 1600 will generate 1,600 psi for maximum output for your Dexter disc brakes. The sealed, weather tight housing contains the electronics necessary to control the high pressure piston pump and proportioning valve for smooth, efficient braking.

Electrical Schematic

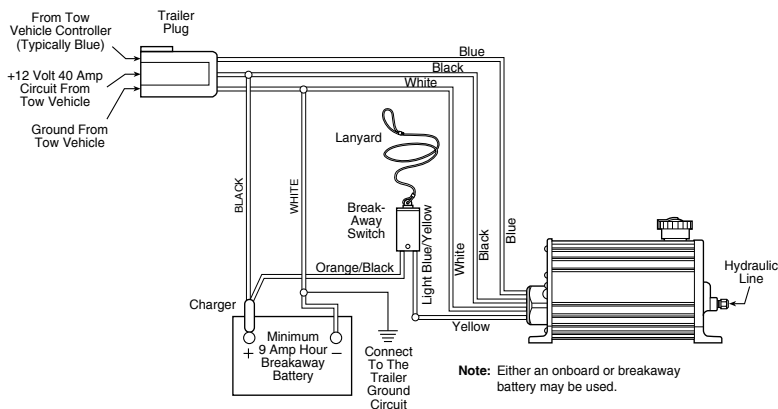



Scan to view
E/H Actuator Installation video

Troubleshooting Guide

Brakes are slow to respond

1. Re-bleed the trailer brakes and actuator.
2. If the trailer is equipped with drum brakes, readjust the drum brakes to the brake manufacture's recommended running clearance.
3. Slow response can be caused by trailer wiring that is too small.
4. For trailers where the E/H brake actuator is located less than 10 feet from the tow vehicle, 12 gage wire is recommended for the black and white wires between the tow vehicle and the E/H brake actuator. All other wires should be a minimum of 16 gauge.
5. For trailers where the E/H brake actuator is located more than 10 feet from the tow vehicle, 10 gage wire is recommended for the black and white wires between the tow vehicle and the E/H brake actuator. All other wires should be a minimum of 16 gauge.
6. Slow response can be caused by improper adjustment of the brake controller. On inertia-based electronic brake controls, adjust the pendulum (inertia sensor) to a more aggressive setting and/or increase the gain setting.

Unit will not run when the ignition is on and the brake pedal is depressed

1. Verify that the trailer and tow vehicle are wired as detailed on the electrical schematic.
2. With the ignition switch on and the brakes not applied, you should have 12-13 volts between the black and white wires on the E/H brake actuator.
3. Clean and replace the ground between the trailer and the E/H brake actuator.
4. Test operation of the unit using the breakaway test procedure.

Breakaway test procedure - do not leave the breakaway switch pulled for more than two minutes during any of the steps outlined below

1. Pull the breakaway switch on the trailer.
2. If the unit runs and builds pressure, that indicates the actuator is functioning properly. The problem most likely is a defective electronic brake controller in the tow vehicle or defective wiring between the tow vehicle and the E/H brake actuator.
3. If the unit runs but will not build pressure, the problem most likely is a defective solenoid valve in the E/H brake actuator and the actuator should be replaced.
4. If the unit still does not run after the breakaway battery is fully charged, verify that the voltage between the white wire and yellow wire is at least 12 volts.
5. If the voltage is less than 12 volts, either the breakaway switch or the breakaway wiring is defective.
6. If the voltage is greater than 12 volts, the E/H brake actuator should be replaced.

Trailer brakes too aggressive

1. Reduce the gain setting on the in-cab electronic brake controller.

General Maintenance - Hydraulic Brakes

Drum Brake Adjustment - Manual

Most Dexter 12 1/4" hydraulic brakes have a self adjusting feature. If manual adjusting is required, use the following procedure:

Brakes should be adjusted (1) after the first 200 miles of operation when the brake shoes and drums have "seated," (2) at 3,000 mile intervals, (3) or as use and performance requires. The brakes should be adjusted in the following manner:

1. Jack up trailer and secure on adequate capacity jack stands. Follow trailer manufacturer's recommendations for lifting and supporting the unit. Make sure the wheel and drum rotates freely.

CAUTION

Do not lift or support the trailer on any part of the axle or suspension system. Never go under any trailer unless it is properly supported on jack stands which have been rated for the load. Improperly supported vehicles can fall unexpectedly and cause serious injury or death.

2. Remove the adjusting hole cover from the adjusting slot on the bottom of the brake backing plate.
3. With a screwdriver or standard adjusting tool, rotate the star wheel of the adjuster assembly to expand the brake shoes. Adjust the brake shoes out until the pressure of the linings against the drum makes the wheel very difficult to turn.

Note: For drop spindle axles, a modified adjusting tool may be necessary.

4. Then rotate the star wheel in the opposite direction until the wheel turns freely with a slight lining drag.
5. Replace the adjusting hole cover and lower the wheel to the ground.
6. Repeat the above procedure on all brakes. For best results, the brakes should all be set at the same clearance.

Most of the brake components are very similar to those used in electric brakes, and maintenance is comparable for the hub and drum, shoes and linings, and bearings. Specific maintenance activities are as follows:

Wheel Cylinders

Inspect for leaks and smooth operation. Clean with brake cleaner and flush with fresh brake fluid. Hone or replace as necessary.

Brake Lines

Check for cracks, kinks, or blockage. Flush with fresh brake fluid. Bleed system to remove all air. Replace as necessary.

Shoes and Linings

A simple visual inspection of your brake linings will tell if they are usable. Replacement is necessary if the lining is worn (to within 1/16" or less), contaminated with grease or oil, or abnormally scored or gouged. Hairline heat cracks are normal in bonded linings and should not be cause for concern. When replacement is necessary, it is important to replace both shoes on each brake and both brakes of the same axle. This will help retain the "balance" of your brakes.



CAUTION

POTENTIAL ASBESTOS DUST HAZARD!

Some older brake linings may contain asbestos dust, which has been linked to serious or fatal illnesses. Certain precautions need to be taken when servicing brakes:

1. **Avoid creating or breathing dust.**
2. **Avoid machining, filing or grinding the brake linings.**
3. **Do not use compressed air or dry brushing for cleaning (dust can be removed with a damp brush).**

After replacement of brake shoes and linings, the brakes must be re-burnished to seat in the new components. This should be done by applying the brakes 20 to 30 times from an initial speed of 40 m.p.h., slowing the vehicle to 20 m.p.h. Allow ample time for brakes to cool between applications. This procedure allows the brake shoes to seat in to the drum surface.

Hardware

Check all hardware. Check shoe return spring, hold down springs, and adjuster springs for stretch or wear. Replace as required. Service kits are available.

Instructions for Brake Caliper Kit 3.5K Hydraulic Disc Brakes

Notice to Buyer

It is recommended that all brakes be replaced at the same time to ensure balanced braking performance.

Remove the old brake caliper

1. Jack up trailer and secure on adequate capacity jack stands. Follow trailer manufacturers recommendations for lifting and supporting the unit.



CAUTION

Do not lift or support the trailer on any part of the axle or suspension system. Never go under any trailer unless it is properly supported on jack stands which have been rated for the load. Improperly supported vehicles can fall unexpectedly and cause serious injury or death.

2. Remove the wheel from the hub, leaving the brake exposed.
3. Disable the brake actuation system. Check that the hydraulic system has zero pressure and that the hub and rotor rotate freely.
4. Remove the hose from the caliper, then remove the two caliper mounting bolts. Do not allow the caliper to hang from the hose.

Installing the new brake caliper

1. First, inspect the brake assembly for grooves, flaking, cracks, heat checking, thickness variation, insufficient rotor thickness, and look to see that the mounting hardware is straight. Replace any component as needed (or desired) per manufacturer recommendations.
2. Install the new caliper assembly. Make sure that the bleed screw points up.
3. Remount the caliper assembly onto the caliper attaching bracket. Ensure that there is thread locking compound on the threads of the new mounting bolts. Torque mounting bolts to **40-50 Ft. Lbs.**

Note: Use two lug nuts to secure rotor against the hub face when reassembling the caliper. After the caliper is assembled remove the lug nuts.

4. Reconnect the hose to the elbow adapter on the back of the caliper and torque to **10-12 Ft. Lbs.**
5. Reconnect the brake actuation system. Refer to your actuation systems Operation Maintenance Service Manual for proper operation.
6. Bleed and flush brake system per your actuation systems Operation Maintenance Service Manual.
7. Remount the wheel. Refer to your Operation Maintenance Service Manual for proper wheel nut torque procedures.

Instructions for Brake Rotor Kit 3.5K Hydraulic Disc Brakes

Notice to Buyer

It is recommended that all brakes be replaced at the same time to ensure balanced braking performance.

Remove the old brake rotor

1. Jack up trailer and secure on adequate capacity jack stands. Follow trailer manufacturers recommendations for lifting and supporting the unit.

 **CAUTION**

Do not lift or support the trailer on any part of the axle or suspension system. Never go under any trailer unless it is properly supported on jack stands which have been rated for the load. Improperly supported vehicles can fall unexpectedly and cause serious injury or death.

2. Remove the wheel from the hub, leaving the brake exposed.
3. Disable the brake actuation system. Check that the hydraulic system has zero pressure and that the hub and rotor rotates freely.
4. Remove the two caliper mounting bolts. Do not allow the caliper assembly to hang from the hose. Do not disconnect the hose or allow air into the hydraulic system.
5. With the caliper assembly out of the way remove the brake rotor. Save the brake mounting hardware for reinstalling the brake calipers.

Installing the new brake rotor

1. First inspect the brake assembly for grooves, flaking, cracks, heat checking, thickness variation, insufficient rotor thickness, and look to see that the mounting hardware is straight. Replace any component as needed (or desired) per manufacturer recommendations.
2. Install the new brake rotor by fitting it onto the hub flush with the hub face.
3. Remount the caliper assembly onto the caliper attaching bracket. Place thread locking compound on threads of mounting bolts. Torque mounting bolts to **40-50 Ft. Lbs.**

Note: Use two lug nuts to secure rotor against the hub face when reassembling the calipers. After the calipers are assembled remove the lug nuts.

4. Reconnect the brake actuation system. Refer to your Operation Maintenance Service Manual for proper operation.
5. Remount the wheel. Refer to your Operation Maintenance Service Manual for proper wheel nut torque procedures.

Instructions for Brake Rotor Kit 6K or 8K Hydraulic Disc Brakes

Notice to Buyer

It is recommended that all brakes be replaced at the same time to ensure balanced braking performance.

Remove the old brake rotor

1. Jack up trailer and secure on adequate capacity jack stands. Follow trailer manufacturers recommendations for lifting and supporting the unit.



CAUTION

Do not lift or support the trailer on any part of the axle or suspension system. Never go under any trailer unless it is properly supported on jack stands which have been rated for the load. Improperly supported vehicles can fall unexpectedly and cause serious injury or death.

2. Remove the wheel from the hub, leaving the brake exposed.
3. Disable the brake actuation system. Check that the hydraulic system has zero pressure and that the hub and rotor rotates freely.
4. For brakes produced after April 2008, locate the crossover brake line threaded into the bottom side of both calipers. The crossover brake line is attached to the inboard side of the anchor yoke using a metal tube clamp. Remove the 1/4-20 bolt that connects the tube clamp to the yoke.
5. Remove the four caliper mounting bolts. Do not allow the caliper assembly to hang from the hose. Do not disconnect the hose or allow air into the hydraulic system.
6. With the caliper assembly out of the way remove the brake rotor. Save the brake mounting hardware for reinstalling the brake calipers.

Installing the new brake rotor

1. First inspect the brake assembly for grooves, flaking, cracks, heat checking, thickness variation, insufficient rotor thickness, and look to see that the mounting hardware is straight. Replace any component as needed (or desired) per manufacturer recommendations.
2. Install the new brake rotor by fitting it onto the hub flush with the hub face.
Note: Use two lug nuts to secure rotor against the hub face when reassembling the calipers. After the calipers are assembled remove the lug nuts.
3. Remount the caliper assembly onto the caliper attaching bracket. It may be necessary to push the piston into the calipers to obtain enough clearance. Torque mounting bolts to **25-35 Ft. Lbs.**
4. For brakes produced after April 2008, locate the tube clamp attached to the crossover brake line and attach to the caliper mounting bracket. Using the 1/4-20 bolt, torque to **85-100 In. Lbs.**
5. Spin the rotor to ensure that there is enough clearance between the rotor and the crossover brake line.
6. Reconnect the brake actuation system. Refer to your Operation Maintenance Service Manual for proper operation.
7. Remount the wheel. Refer to your Operation Maintenance Service Manual for proper wheel nut torque procedures.
8. Spin the wheel to ensure that there is enough clearance between the wheel and crossover brake line or caliper.

Instructions for Brake Hub/Rotor Kit 7K Hydraulic Disc Brakes

Notice to Buyer

It is recommended that all brakes be replaced at the same time to ensure balanced braking performance.

Remove the old brake rotor

1. Jack up trailer and secure on adequate capacity jack stands. Follow trailer manufacturers recommendations for lifting and supporting the unit.

CAUTION

Do not lift or support the trailer on any part of the axle or suspension system. Never go under any trailer unless it is properly supported on jack stands which have been rated for the load. Improperly supported vehicles can fall unexpectedly and cause serious injury or death.

2. Remove the wheel from the hub, leaving the brake exposed.
3. Disable the brake actuation system. Check that the hydraulic system has zero pressure and that the hub/rotor rotates freely.
4. For brakes produced after April 2008, locate the crossover brake line threaded into the bottom side of both calipers. The crossover brake line is attached to the inboard side of the anchor yoke using a metal tube clamp. Remove the 1/4-20 bolt that connects the tube clamp to the yoke.
5. Remove the four caliper mounting bolts. Do not allow the caliper assembly to hang from the hose. Do not disconnect the hose or allow air into the hydraulic system.
6. With the caliper assembly out of the way, remove the brake rotor by removing the grease or oil cap, spindle nut and outer bearing, then pull hub/rotor off the spindle.

Installing the new brake hub/rotor

1. First inspect the brake assembly for grooves, flaking, cracks, heat checking, thickness variation, insufficient rotor thickness, and look to see that the mounting hardware is straight. Replace any component as needed (or desired) per manufacturer recommendations.
2. Install the new brake hub/rotor assembly and outer bearing onto axle spindle.
3. Install washer and spindle nut onto spindle to secure hub. Install nut per the bearing adjustment procedure in your Operation Maintenance Service Manual.

4. Ensure spindle nut retainer is in place. Install new grease or oil cap with rubber plug, and torque as shown on cap.
5. Remount the caliper assembly onto the caliper attaching bracket. It may be necessary to push the piston into the calipers to obtain enough clearance. Torque mounting bolts to **25-35 Ft. Lbs.**
6. For brakes produced after April 2008, locate the tube clamp attached to the crossover brake line and attach to the caliper mounting bracket. Using the 1/4-20 bolt, torque to **85-100 In. Lbs.**
7. Spin the hub/rotor to ensure that there is enough clearance between the rotor and the crossover brake line.
8. Reconnect the brake actuation system. Refer to your Operation Maintenance Service Manual for proper operation.
9. Remount the wheel. Refer to your Operation Maintenance Service Manual for proper wheel nut torque procedures.
10. Spin the wheel to ensure that there is enough clearance between the wheel and crossover brake line or caliper.

Instructions for Brake Pad Kit 6K, 7K or 8K Hydraulic Disc Brakes

Notice to Buyer

It is recommended that all brakes be replaced at the same time to ensure balanced braking performance.

Remove the old brake pads

1. Jack up trailer and secure on adequate capacity jack stands. Follow trailer manufacturers recommendations for lifting and supporting the unit.

CAUTION

Do not lift or support the trailer on any part of the axle or suspension system. Never go under any trailer unless it is properly supported on jack stands which have been rated for the load. Improperly supported vehicles can fall unexpectedly and cause serious injury or death.

2. Remove the wheel from the hub, leaving the brake exposed.
3. Disconnect the brake actuation system. Check that the hydraulic system has zero pressure and that the hub and rotor rotates freely.
4. Remove the brake pad retaining pin.
5. Remove the old pads from the caliper assembly. Save the brake pad retaining hardware for reinstalling the new pads onto the caliper.

CAUTION

POTENTIAL ASBESTOS DUST HAZARD!

Some older brake linings may contain asbestos dust, which has been linked to serious or fatal illnesses. Certain precautions need to be taken when servicing brakes:

1. **Avoid creating or breathing dust.**
2. **Avoid machining, filing or grinding the brake linings.**
3. **Do not use compressed air or dry brushing for cleaning (dust can be removed with a damp brush).**

Installing the new brake pads

1. First inspect the brake assembly for grooves, flaking, cracks, heat checking, thickness variation, insufficient rotor thickness, and look to see that the mounting hardware is straight. Replace any component as needed (or desired) per manufacturer recommendations.
2. Press the caliper pistons into the calipers until enough clearance is available to fit the new pads between the pistons and the rotor.

Note: Use two lug nuts to secure rotor against the hub face when reassembling the new pads. After the pads are assembled remove the lug nuts.

3. Install the new brake pads by sliding them in one at a time between the caliper pistons and the rotor. The pads are the same for the inner and outer side of the rotor. Make sure the brake lining side of the pad faces the rotor, and the steel backing faces the caliper pistons.
4. Align the brake pad mounting holes with the holes in the caliper. Insert one of two brake pad retaining bolts into each caliper half as shown below in **Figure 1**. Place the anti-rattle spring against the brake pads and press the center toward the rotor while you slide the outboard pad retaining bolt toward the inner lining. Continue sliding the pad retainer bolts until it engages both pads and pushes the second bolt out of the inboard caliper half. Install and torque lock nut until threads stop.

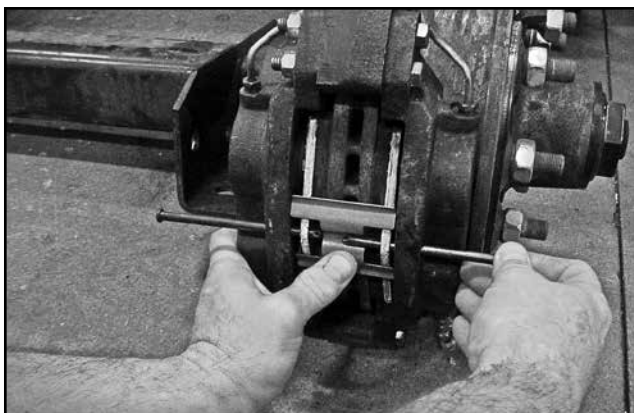

Figure 1

5. Reconnect the brake actuation system. Refer to your Operation Maintenance Service Manual for proper operation.
6. Remount the wheel. Refer to your Operation Maintenance Service Manual for proper wheel nut torque procedures.

Instructions for Brake Caliper Kit 6K, 7K or 8K Hydraulic Disc Brakes

Notice to Buyer

It is recommended that all brakes be replaced at the same time to ensure balanced braking performance.

Remove the old brake calipers

1. Jack up trailer and secure on adequate capacity jack stands. Follow trailer manufacturers recommendations for lifting and supporting the unit.



CAUTION

Do not lift or support the trailer on any part of the axle or suspension system. Never go under any trailer unless it is properly supported on jack stands which have been rated for the load. Improperly supported vehicles can fall unexpectedly and cause serious injury or death.

2. Remove the wheel from the hub, leaving the brake exposed.
3. Disable the brake actuation system. Check that the hydraulic system has zero pressure and that the hub and rotor rotates freely.
4. For brakes produced after April 2008, the crossover brake line also attaches to the inboard side of the caliper mounting bracket using the metal tube clamp. Slide the clamp over the crossover brake line and bend it to the closed position. Apply anti-seize or similar thread lubricant to the 1/4-20, 1/2" bolt. Attach the tube clamp to the threaded hole in the caliper mounting bracket using the 1/4-20, 1/2" length bolt. Torque to **85-100 In. Lbs.**
5. Remove the hose from the caliper, then remove the four caliper mounting bolts. Do not allow the caliper to hang from the hose.

Installing the new brake caliper

1. First inspect the brake assembly for grooves, flaking, cracks, heat checking, thickness variation, insufficient rotor thickness, and look to see that the mounting hardware is straight. Replace any component as needed (or desired) per manufacturer recommendations.

2. Assemble the new caliper assembly.

Note: Use two lug nuts to secure rotor against the hub face when reassembling the calipers. After the brake is assembled, remove the lug nuts.

3. One caliper will be used on the inboard side, with the hydraulic line fitting adapter installed on the top side of the piston boss. The other caliper will be used on the outboard side with the bleed screw installed at the top of the piston boss. Install both of these calipers onto the attaching bracket. Make sure that the bleed screw points up and is located on the outboard caliper. Torque bolts to **25-35 Ft. Lbs.**
4. Connect the new crossover brake line on the bottom sides of the piston boss on both calipers.

Note: Make sure the crossover line fits snug around the calipers and rotor without touching the rotor. Spin the rotor to ensure there is proper clearance. Torque the crossover line to **12-15 Ft. Lbs.** Torque the bleed screw and the hydraulic line fitting adapter to **60-76 Inch Lbs.**

5. For brakes produced after April 2008, locate the crossover brake line threaded into the bottom side of both calipers. The crossover brake line is attached to the inboard side of the anchor yoke using a metal tube clamp. Remove the 1/4-20 bolt that connects the tube clamp to the yoke.
6. Reassemble the brake pads into the disc brake. Make sure to locate the brake lining side of the pads toward the rotor surface, and the steel side of the pads toward the calipers. Align the brake pad mounting holes with the holes in the caliper. Insert one of two brake pad retaining bolts into each caliper half as shown previously in **Figure 1**. Place the anti-rattle spring against the brake pads and press the center toward the rotor while you slide the outboard pad retaining bolt toward the inner lining. Continue sliding the pad retainer bolt until it engages both pads and pushes the second bolt out of the inboard caliper half. Install and torque locknut until threads stop.

7. Reconnect the brake actuation system. Refer to your Operation Maintenance Service Manual for proper operation.
8. Bleed and flush brake system per your actuation systems Operation Maintenance Service Manual.
9. Remount the wheel. Refer to your Operation Maintenance Service Manual for proper wheel nut torque procedures.
10. Spin wheel to ensure proper clearance between the wheel and crossover brake line or caliper.

Introduction to Troubleshooting

Proper brake function is critical to the safe operation of any vehicle. A properly installed vacuum/hydraulic, electric/hydraulic, or air/hydraulic system should not require any special attention with the exception of routine maintenance as defined by the manufacturer. If problems occur, the entire tow vehicle/trailer braking system should be analyzed by a qualified mechanic. Typical problems in a hydraulic braking system are:

- Air or vacuum leaks
- Hydraulic system leaks
- Air in brake lines
- Water or other impurity in brake fluid
- Rusted or corroded master or wheel cylinders
- Actuation system malfunction

Please consult the following troubleshooting charts to determine the causes and solutions for common problems found in trailer braking systems.

CAUTION

The maximum operating pressure for Dexter brakes:

- **7" diameter drum brakes**
maximum operating pressure is 750 psi
- **10" diameter and larger drum brakes**
maximum operating pressure is 1,000 psi
- **Hydraulic disc brakes (all sizes)**
maximum operating pressure is 1,600 psi

Troubleshooting

SYMPTOM	CAUSES	REMEDIES
No Brakes	Broken or Kinked Brake Line	Repair or Replace
	Severe Underadjustment	Adjust Brakes
	Malfunctioning Actuation System	Troubleshoot System
Weak Brakes	Brake Adjustment Not Correct	Manual-Adjust Brakes Automatic-Make Several Reverse Stops
	Excessively Worn Brake Linings	Replace Shoe and Lining
	Incorrect Lining	Install Correct Shoe and Lining
	Grease or Fluid Soaked Lining	Repair Grease Seal or Wheel Cylinder. Install New Shoe and Lining.
	Frozen Master Cylinder or Wheel Cylinder Pistons	Recondition or Replace All Cylinders, Brake Fluid
	Glazed Lining	Reburnish or Replace
	Excessive Drum Wear	Replace
	Trapped Air in Lines	Bleed System
Harsh Brakes	Overloaded Trailer	Correct
	Malfunctioning Actuating System	Troubleshoot System
Surging Brakes	Brake Adjustment Not Correct	Manual-Adjust Brakes Automatic-Make Several Reverse Stops
	Grease or Fluid on Linings	Replace Shoes and Linings
Surging Brakes	Grease or Oil on Linings	Clean or Replace
	Out of Round Drums or Cracked Drums	Machine or Replace

Troubleshooting

SYMPTOM	CAUSES	REMEDIES
Noisy Brakes	Underadjustment	Adjust
	Lack of Lubrication	Lubricate
	Broken Brake Components	Replace Components
	Incorrect Brake Components	Correct
Locking Brakes	Loose, Bent or Broken Brake Components	Replace Components
	Underadjustment	Adjust
	Out-of-Round Drums	Machine or Replace
Pulls to One Side	Incorrect Tire Pressure	Inflate Evenly on Both Sides to Req. Pressures
	Unmatched Tires on Same Axle	Match Tires on Axle
	Restricted Brake Lines or Hoses	Repair or Replace
	Malfunctioning Cylinder Assembly	Check for Stuck or Sluggish Pistons
	Defective or Damaged Shoe and Lining	Install New Shoe and Lining-Complete Axle
	One Side Out-of-Adjustment	Adjust
Dragging	Improper Fluid	Replace Rubber Parts Fill with DOT4 Fluid
	Blocked Master Cylinder	Open with Compressed Air or Replace Cylinder
	Parking Brake Cable Frozen	Free Cable and Lubricate
	Improper Lining Thickness or Location	Install New Shoes and Linings

Hubs/Drums/Bearings

Dexter offers several types of bearing arrangements and lubrication methods.

- Dexter's standard wheel bearing configuration consists of opposed tapered roller bearing cones and cups, fitted inside of a precision machined cast hub. This method of using tapered roller bearings requires that a minimal amount of axial end play be provided at assembly. This end play is essential to the longevity of the bearings service life. This design is typically lubricated with grease, packed into the bearings. Oil lubrication is another method which is available in some of the larger axle capacities.
- E-Z Lube® is another option chosen by some trailer manufacturers. If your axle is equipped with the Dexter E-Z Lube® feature, the bearings can be periodically lubricated without removing the hubs from the axle. This feature consists of axle spindles that have been specially drilled and assembled with grease fittings in their ends. When grease is pumped into the fitting, it is channeled to the inner bearing and then flows back to the outer bearing and eventually back out the grease cap hole.
- Nev-R-Lube® option is the latest innovation from Dexter. Nev-R-Lube® bearings are comprised of opposed tapered roller bearing cones sealed inside of a precision ground, one piece double cup arrangement. These bearings are designed with a small amount of axial end play. This end play is essential to the longevity of the bearings service life. They are lubricated, assembled and sealed at the factory. No further lubrication is ever needed.

Before attempting any disassembly of your Dexter axle, make sure you read and follow the instructions for the appropriate axle type.



Scan to view
Bearing Maintenance video

Hub Removal - Standard Bearings

Whenever the hub equipment on your axle must be removed for inspection or maintenance the following procedure should be utilized.

1. Elevate and support the trailer unit per manufacturers' instructions.



CAUTION

You must follow the maintenance procedures to prevent damage to important structural components. Damage to certain structural components such as wheel bearings can cause the wheel end to come off of the axle. Loss of a wheel end while the trailer is moving can cause you to lose control and lead to an accident, which can result in serious injury or death.

2. Remove the wheel.
3. Remove the grease cap by carefully prying progressively around the flange of the cap. If the hub is an oil lube type, then the cap can be removed by unscrewing it counterclockwise while holding the hub stationary.
4. Remove the cotter pin from the spindle nut.

For E-Z Lube® axles produced after February of 2002, a new type of retainer is used. Gently pry off retainer from the nut and set aside.
5. Unscrew the spindle nut (counterclockwise) and remove the spindle washer.
6. Remove the hub from the spindle, being careful not to allow the outer bearing cone to fall out. The inner bearing cone will be retained by the seal.

Brake Drum Inspection

There are two areas of the brake drum that are subject to wear and require periodic inspection. These two areas are the drum surface where the brake shoes make contact during stopping and the armature surface where the magnet contacts (only in electric brakes).

The drum surface should be inspected for excessive wear or heavy scoring. If worn more than .020" oversized, or the drum has worn out of round by more

than .015", then the drum surface should be re-machined. If scoring or other wear is greater than .090" on the diameter, the drum must be replaced. When turning the drum surface, the maximum rebore diameter is as follows:

- 7" Brake Drum-7.090" diameter
- 10" Brake Drum-10.090" diameter
- 12" Brake Drum-12.090" diameter
- 12 1/4" Brake Drum-12.340" diameter
- 6K, 7K and 8K Rotor-1.03" minimum thickness
- 3.5K Rotor-.85" minimum thickness

The machined inner surface of the brake drum that contacts the brake magnet is called the armature surface. If the armature surface is scored or worn unevenly, it should be refaced to a 120 micro inch finish by removing not more than .030" of material. To ensure proper contact between the armature face and the magnet face, the magnets should be replaced whenever the armature surface is refaced and the armature surface should be refaced whenever the magnets are replaced.

Note: It is important to protect the wheel bearing bores from metallic chips and contamination which result from drum turning or armature refacing operations. Make certain that the wheel bearing cavities are clean and free of contamination before reinstalling bearing and seals. The presence of these contaminants will cause premature wheel bearing failure.

Bearing Inspection

Wash all grease and oil from the bearing cone using a suitable solvent. Dry the bearing with a clean, lint-free cloth and inspect each roller completely.

CAUTION

**Never spin the bearing with compressed air.
THIS CAN DAMAGE THE BEARING.**

If any pitting, spalling, or corrosion is present, then the bearing must be replaced. The bearing cup inside the hub must be inspected.

IMPORTANT: Bearings must always be replaced in sets of a cone and a cup.

 **CAUTION**

Be sure to wear safety glasses when removing or installing force fitted parts. Failure to comply may result in serious eye injury.

When replacing the bearing cup proceed as follows:

1. Place the hub on a flat work surface with the cup to be replaced on the bottom side.
2. Using a brass drift punch, carefully tap around the small diameter end of the cup to drive out.
3. After cleaning the hub bore area, replace the cup by tapping in with the brass drift punch. Be sure the cup is seated all the way up against the retaining shoulder in the hub.

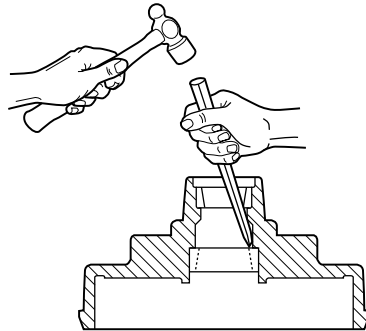

Replace only with bearings as specified in the Bearing Replacement Chart.

Bearing Lubrication - Grease

CAUTION

Do not mix Lithium, calcium, sodium or barium complex greases due to possible compatibility problems. When changing from one type of grease to another, it is necessary to ensure all the old grease has been removed.

Along with bearing adjustment, proper lubrication is essential to the proper function and reliability of your trailer axle. Bearings should be lubricated every 12 months or 12,000 miles. The method to repack bearing cones is as follows:

1. Place a quantity of grease into the palm of your hand.
2. Press a section of the widest end of the bearing into the outer edge of the grease pile closest to the thumb forcing grease into the interior of the bearing.
3. Repeat this while rotating the bearing from roller to roller.
4. Continue this process until you have the entire bearing completely filled with grease.
5. Before reinstalling, apply a light coat of grease on the bearing cup.

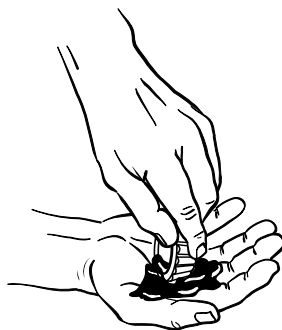

Bearing Lubrication - Oil

If your axles are equipped with oil lubricated hubs, periodically check and refill the hub as necessary with a high quality hypoid gear oil to the level indicated on the clear plastic oil cap. The oil can be filled from either the oil fill hole, if present, in the hub or through the rubber plug hole in the cap itself.

Recommended Wheel Bearing Lubrication Specifications

Grease

Thickener Type	Lithium Complex
Dropping Point	215°C (419°F) Minimum
Consistency	NLGI No. 2
Additives	EP, Corrosion & Oxidation Inhibitors
Viscosity Index	80 Minimum

Approved Grease Sources

Chem Arrow	Arrow 2282
Chevron Texaco	Chevron Ulti-Plex Grease EP #2 Texaco Starplex Moly MPGM #2
Citgo	Lithoplex MP #2 Lithoplex CM #2 Mystik JT-6 Hi-Temp Grease #2
ConocoPhillips/ 76 Lubricants/Kendall	Multiplex RED #2 L427 Super Blu Grease
Dexter Company	Lithoplex Red MP #2
Exxon/Mobil Company	Ronex, MP Mobilith AW 2 Mobil I Synthetic Grease
Fuchs	Renolit Uniwrl 2
Great Plains Lubricants	Lithium Complex EP #2
Oil Center Research of Oklahoma	Liquid-O-Ring No, 167L
Pennzoil-Quaker State Company	Synthetic Red Grease
Royal Mfg. Company	Royal 98 Lithium Complex EP #2
Shell	Gadus S3 V220C Gadus S5 V220 Rotella Heavy Duty Lithium Complex #2
Valvoline	Valvoline Multi-Purpose GM Valvoline DuraBlend

Oil

SAE 90, SAE 80W-90, SAE 75W-90

Approved Oil Sources

Ashland Oil	Valvoline DuraBlend
CITGO Petroleum Co.	CITGO Premium Gear Oil MP Mystik JT-7 Mystik Power Lube
Conoco	Universal Gear Lubricant 80W-90
Exxon Company USA	Gear Oil GX 80W-90
Industrial Oils Unlimited	Super MP Gear Oil 80W-90
Kendall Refining Co.	Kendall NS-MP Hypoid Gear Lube
Lubriplate Division/ Fiske Brothers Refining	Lubriplate APG 90
MFA Oil Company	Multi-Purpose Gear Oil 80W-90
Mobil Oil Corporation	Mobilube SHC Mobil 1 Synthetic Gear Lube
Phillips 66 Petroleum	Superior Multi-Purpose Gear Oil Philguard Gear Oil Philsyn Gear Oil
Pennzoil Products Co.	Gear Plus 80W-90 GL-5 Gear Plus Super 75W-90 Gear Plus Super EW 80W-90 Multi-Purpose 4092 Gear Lube
Oil Center Research	Liquid-O-Ring 750 GX
Sun Refining and Marketing Company	Sunoco Ultra Sunoco Dura Gear
Shell Oil Company	Spirax A Spirax G Spirax HD Spirax S
Texaco Oil Company	Multigear EP Multigear SS
Troco Division/ Royal Manufacturing	Multigear Select Gear Oil
Union Oil Company	Unocal MP Gear Lube 76 Triton Syn Lube EP

Note: The convenient lubrication provisions of the E-Z Lube® and the oil lubrication must not replace periodic inspection of the bearings.

Seal Inspection and Replacement

Whenever the hub is removed, inspect the seal to assure that it is not nicked or torn and is still capable of properly sealing the bearing cavity. If there is any question of condition, replace the seal. Use only the seals specified in the Seal Replacement Chart.

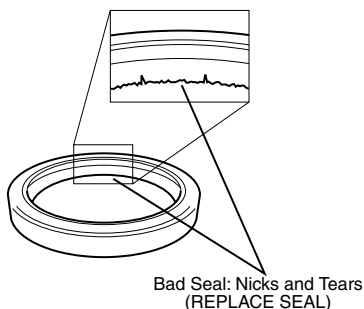

To replace the seal:

1. Pry the seal out of the hub with a seal removal tool or a screwdriver. Never drive the seal out with the inner bearing as you may damage the bearing.
2. Apply a sealant similar to PERMATEX® High-Temp Red RTV Silicone Gasket to the outside of the seal. Use only enough to provide a thin coat to prevent any excess from contaminating the rubber lip(s) of the seal. It is okay to apply a slight amount of lube to the inner rubber lip(s) to aid with installing onto the spindle.

Note: No sealant should be used if the outside of the seal is rubber coated. For these type of seals it is recommended to apply a thin coat of oil to the outside rubber.

3. Clean the seal journal of the spindle to inspect for nicks or roughness. Use a file to remove any burrs from the leading edge or shoulder area. Clean the journal area with very fine emery cloth. Any presence of deep gouges or scratches in this area may cause seal failure allowing lubricant to leak out of the hub.
4. Clean the seal bore in the hub and inspect for any nicks, gouges, or scratches that may prevent the seal from retaining the bearing lubricant inside the hub.

5. Orient the seal properly. Many oil bath seals will be marked AIR SIDE on the side of the seal to facing out of the hub after installation.
6. Install new seal into place using a seal driver or seal installation tool of proper size. It is important that any seal installation tool contact the outer ring of the seal casing. If no seal driver is available, use a clean block of wood. It is critical that the seal be driven in evenly and straight. NEVER hammer directly on the seal.
7. The seals will be pressed flush to the back surface of the hub in the 600-8,000 lbs. capacity product line. It is NEVER necessary to bottom out the seal for proper installation. Driving the seal in too deep may damage the seal and may come in contact with the inner bearing preventing it from rotating freely.
8. Proper installation will maintain the seal flatness in the hub within .010". A seal that is cocked too much inside the hub will be more likely to leak.

Bearing Adjustment and Hub Replacement

If the hub has been removed or bearing adjustment is required, the following adjustment procedure must be followed.

For standard grease or oil axles using cotter pin:

1. After placing the hub, bearings, washers, and spindle nut back on the axle spindle in reverse order as detailed in the previous section on hub removal, rotate the hub assembly slowly while tightening the spindle nut to approximately **50 Ft. Lbs.** (12" wrench or pliers with full hand force.)
2. Then loosen the spindle nut to remove the torque. Do not rotate the hub.
3. Finger tighten the spindle nut until just snug.
4. Back the spindle nut out slightly until the first castellation lines up with the cotter key hole and insert the cotter pin.
5. Bend over the cotter pin legs to secure the nut.
6. Nut should be free to move with only restraint being the cotter pin.

For E-Z Lube® axles using the new nut retainer:

1. After placing the hub, bearings, washers, and spindle nut back on the axle spindle in reverse order as detailed in the previous section on hub removal, rotate the hub assembly slowly while tightening the spindle nut to approximately **50 Ft. Lbs.** (12" wrench or pliers with full hand force.)
2. Then loosen the spindle nut to remove the torque. Do not rotate the hub.
3. Finger tighten the nut until just snug, align the retainer to the machined flat on the spindle and press the retainer onto the nut. The retainer should snap into place. Once in place, the retainer/nut assembly should be free to move slightly.
4. If the nut is too tight, remove the retainer and back the nut off approximately one twelfth of a turn and reinstall the retainer. The nut should now be free to move slightly.
5. Reinstall grease cap.

Typical E-Z Lube® After Spring 2002

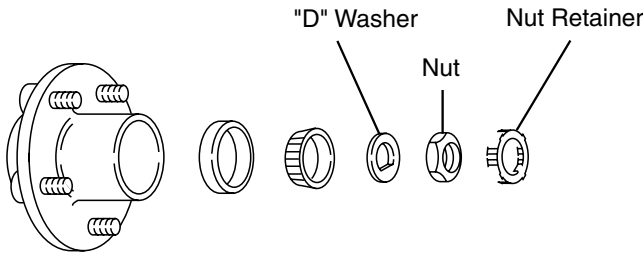

E-Z Lube® Lubrication

The procedure is as follows:

1. Remove the rubber plug from the end of the grease cap.
2. Place a standard manual grease gun onto the grease fitting located in the end of the spindle. Make sure the grease gun nozzle is fully engaged on the fitting.
3. While rotating the hub, pump grease slowly into the fitting. The old displaced grease will begin to flow back out the cap around the grease gun nozzle.

4. When the new clean grease is observed, remove the grease gun, wipe off any excess, and replace the rubber plug in the cap.
5. Rotate hub or drum while adding grease.

Note: The E-Z Lube® feature is designed to allow immersion in water. Axles not equipped with E-Z Lube® are not designed for immersion and bearings should be repacked after each immersion. If hubs are removed from an axle with the E-Z Lube® feature, it is imperative that the seals be replaced BEFORE bearing lubrication. Otherwise, the chance of grease getting on brake linings is greatly increased.

Note: Dexter strongly recommends not using pneumatic powered grease guns as these can inject grease too fast and force grease past the seal, or in rare cases dislodge the seal.

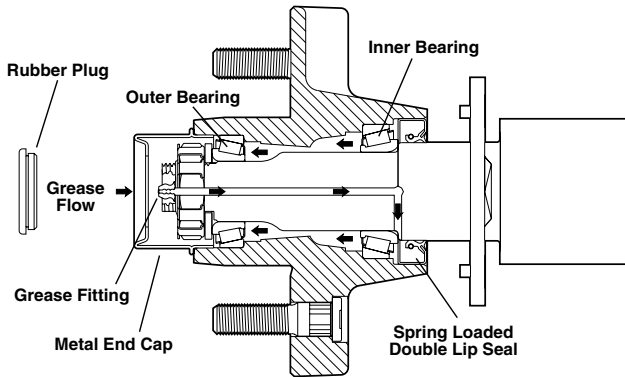

Nev-R-Lube® Drums/Bearings

Dexter's Nev-R-Lube® bearings are comprised of opposed tapered roller bearing cones sealed inside of a precision ground, one piece double cup arrangement. These bearings are designed with a small amount of axial end play. This end play is essential to the longevity of the bearings service life.

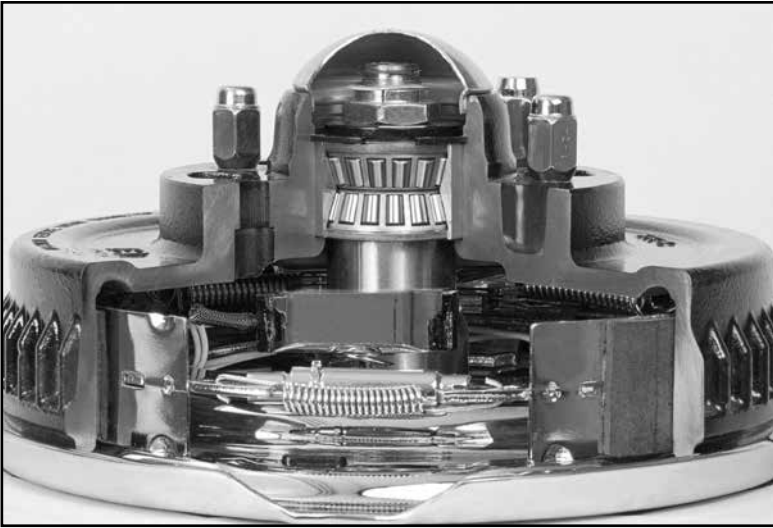

Note: Nev-R-Lube® is not designed for immersion in water, such as boat trailer use.

CAUTION

Dexter has advised trailer manufacturers of certain wheel limitations when used with the Nev-R-Lube® bearings. The offset of the wheel must be as listed. Deviation from these limits will result in limited bearing life and possible catastrophic failure.

- 35MM - use only zero offset wheels
- 42MM - use only zero offset wheels
- 50MM - use only zero offset to .19" wheels

Drum Removal

Whenever the hub equipment on your axle must be removed for inspection or maintenance, the following procedure should be utilized.

1. Elevate and support the trailer unit per manufacturer's instructions.



CAUTION

Do not lift or support the trailer on any part of the axle or suspension system. Never go under any trailer unless it is properly supported on jack stands which have been rated for the load. Improperly supported vehicles can fall unexpectedly and cause serious injury or death.

2. Remove the wheel.
3. Remove the grease cap from the hub by carefully prying progressively around the flange.
4. Remove snap ring on the end of the spindle. Remove "torque instruction" washer.
5. Unscrew the spindle nut (counterclockwise) and remove the spindle washer.
6. Carefully remove the hub from the spindle. The Nev-R-Lube® bearing cartridge will remain in the hub.

Note: Do not remove cartridge bearing from the hub bore unless replacement of the bearing cartridge is intended. Special tools and techniques are required for removal of the old bearing.

Bearing Inspection

Important:

1. Elevate and support the trailer unit per manufacturer's instructions.



CAUTION

Do not lift or support the trailer on any part of the axle or suspension system. Never go under any trailer unless it is properly supported on jack stands which have been rated for the load. Improperly supported vehicles can fall unexpectedly and cause serious injury or death.

2. Check for excessive wheel end clearance by pulling the tire assembly towards you and by pushing the assembly away from you. Slight end play is acceptable.
3. Rotate tire slowly forwards and backwards. The wheel assembly should turn freely and smoothly.
4. Excessive wheel end play, restriction to rotation, noise, or "bumpy" rotation should be remedied by replacing the bearing unit.
5. Bearing units should be inspected every year or 12,000 miles whichever comes first.

Note: A slight amount of grease weeping from the seal area is normal. Excessive leakage may indicate abnormal bearing operation.

Nev-R-Lube® Bearing End Play Inspection

The following lists the maximum axial end play for each of the sizes of Nev-R-Lube® bearings and the amount of tilt that can be expected. Since there are a large number of wheel and tire combinations in use on trailers, the tilt is expressed in inches per inch. The movement as measured at the tire tread can be found by the following method:

Example: if the tilt value is shown as .003" per inch and the tire measures 30" in diameter, simply multiply .003" X 15" (1/2 tire diameter) = .045" which is the total expected movement at the tires' outer diameter.

Bearing Size	End Play	Resultant Tilt Value
35 MM	.005" axial	.003" / per inch
42 MM	.006" axial	.005" / per inch
50 MM	.008" axial	.004" / per inch

It is important to note that most mounted tires will deflect fairly easily when enough hand pressure is applied while shaking the tire. Excessive pressure will result in the perception that the bearings' tilt is greater than it actually is. This same phenomenon will occur when checking any wheel end, even those equipped with conventional bearing sets.

Bearing Replacement and Drum Installation

1. Once the drum and bearing assembly is removed from the axle, remove "internal" snap ring from the bearing bore that retains bearing.
2. Using an arbor press and mandrel, press the bearing out of the drum. Bearing will exit on the wheel side of the drum.
3. When replacing a Nev-R-Lube® bearing pack, the bore in the hub should be cleaned and inspected for visual damage (replace as necessary).
4. Install the new bearing using an arbor press fitted with a hollow or stepped punch face to press only on the outer housing of the bearing. Failure to follow procedure will damage the bearing and/or seals during installation. Press bearing until it seats against the backup shoulder machined into the hub.

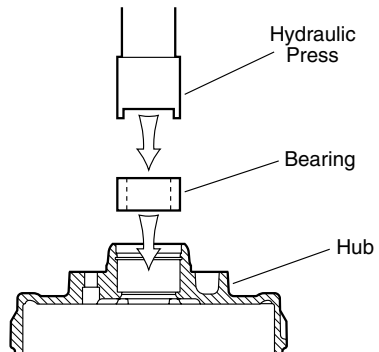
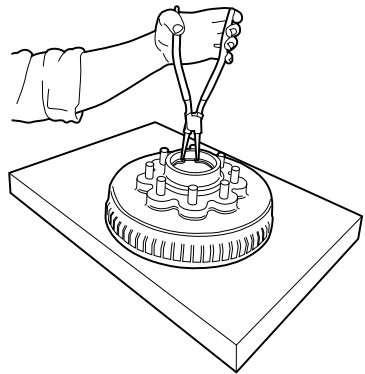

5. Install “internal” snap ring into hub.
6. Clean and inspect spindle shaft. Apply a light coating of anti-seize lubricant to the spindle shaft prior to assembling drum.
7. Install drum assembly onto spindle (Do NOT FORCE).
8. Install steel washer onto spindle end.
9. Start self-locking nut onto spindle thread by hand. Complete installation using a 1 7/16" 6 or 12 point socket and torque wrench. Nut should be torqued to **145-155 Ft. Lbs.** (this torque will set the internal bearing adjustment, no other adjustments are to be made).
10. Install “torque instruction” washer onto end of spindle.
11. Install “external” snap ring onto end of spindle to retain washer.
12. Inspect assembly for excessive end play, noise, and rotation restriction prior to mounting final wheel end hardware.

Axle & Suspension Installation

Responsibility for proper axle alignment lies with the axle installer. The axle must be installed so that it will be parallel to the drive axle(s) of the tractor. This will allow good vehicle control when cornering, longer tire wear, and it will eliminate dog tracking. Alignment can be determined by measuring from the center of the trailer king pin to the center of each end of the axles. The difference should not vary by more than 1/16". In the case of multiple axles, the axles must also be in line with each other. The difference between the centers of one axle and end centers of the other axle must not vary more than 1/8".



CAUTION

Safety glasses should be worn at all times when assembling or disassembling axles and their components.

Dexter tubular axles are made of high strength steel for better fatigue life and superior welding qualities. The round tubular axles provide a uniform section modulus no matter how the beam is rotated.

Suspension Systems

The suspension systems incorporated into Dexter axles are designed to provide the trailer owner three basic functions:

1. Attach the axle to the trailer
2. Dampen the effects of road shock
3. Cushion the cargo or load

All Dexter suspension systems are available in single and multiple axle configurations. The three types most commonly available are double eye leaf spring, slipper spring, and Torflex®.

Double Eye Leaf Springs

Double eye springs have eyes formed in each end of the spring with anti-friction bushings fitted for wear resistance. The springs are held to the axle tube using a system of U-bolts and tie plates and are attached to the trailer as shown.

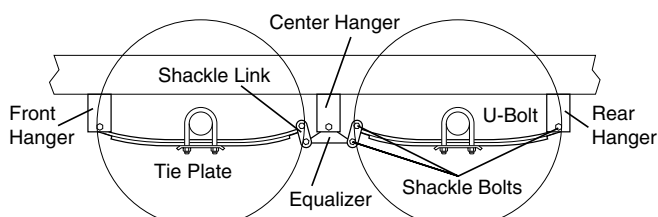

Underslung Shown

Articulation of this suspension occurs when the spring becomes loaded and consequently lengthens. The double pivot action of the shackle links accommodates this articulation and allows the system to move freely.

In multiple axle installations, the action is the same with the additional movement of the equalizer assembly. This serves to transfer instantaneous loads from one axle to another in an effort to “equalize” the load between the axles.

Grease Lubricated Suspension Bushings

Dexter offers a variety of optional heavy duty attaching parts kits for double eye leaf spring suspensions up to 8,000 lb. axle capacity. The kits contain extra heavy shackle links, bronze bushings for the spring eyes, and suspension bolts and equalizers equipped with grease fittings to provide a convenient means to lubricate all the pivot points including the rubber E-Z Flex® equalizer center bushings. For availability, contact your nearest Dexter facility or visit us online at www.dexteraxle.com for a complete listing of genuine repair parts.

Slipper Leaf Springs

Slipper springs have an eye formed in one end only, with the other end formed into a reverse curve. The attachment of these springs is as follows:

1. The front eye is attached directly into the front hanger with a bolt and nut.
2. The rear end of the spring is captured in the rear hanger or equalizer with a “keeper bolt” that prevents the spring from coming out when the trailer is jacked up for service.

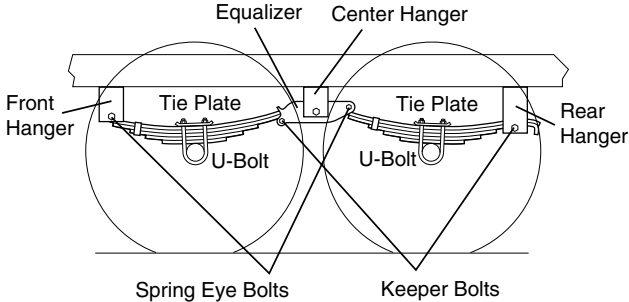

Overslung Shown

The articulation of this suspension occurs when the rear end of each slipper spring slides against the wear surfaces provided in the rear hangers or equalizers. This suspension is also available in single and multiple axle configurations.

Inspection and Replacement

All the components of your suspension system should be visually inspected at least every 6,000 miles for signs of excess wear, elongation of bolt holes, and loosening of fasteners. Whenever loose or replaced, the fasteners in your suspension system should be torqued as detailed in the charts below. All wet bolts and equalizers should be greased every 3,000 miles.



CAUTION

You must follow the maintenance procedures to prevent damage to important structural components. Damage to certain structural components such as wheel bearings can cause the wheel to come off of the axle. Loss of a wheel end while the trailer is moving can cause you to lose control and lead to an accident, which can result in serious injury or death.

Suspension Fastener Torque Values

Item	Torque (Ft. Lbs.)	
	Min	Max
3/8" U-Bolt	30	50
7/16" U-Bolt	45	70
1/2" U-Bolt	70	80
1/2" U-Bolt/Hex Nut	45	70
1/2" Flange Nut	70	80
9/16" U-Bolt	65	95
5/8" U-Bolt	100	120
Non shoulder type with 9/16" threads		
Shackle Bolt	Snug fit only. Parts must rotate freely. Locking nuts or cotter pins are provided to retain nut-bolt assembly.	
Spring Eye Bolt		
Equalizer Bolt		
Shoulder Type	30	50
Shackle Bolt with 7/16" threads		

Worn spring eye bushings, sagging springs, or broken springs should be replaced using the following method.

1. Support the trailer with the wheels just off the ground.

CAUTION

Do not lift or support the trailer on any part of the axle or suspension system. Never go under any trailer unless it is properly supported on jack stands which have been rated for the load. Improperly supported vehicles can fall unexpectedly and cause serious injury or death.

2. After the unit is properly supported place a suitable block under the axle tube near the end to be repaired. This block is to support the weight of the axle only, so that suspension COMPONENTS can be removed.
3. Disassemble the U-bolts, nuts, and tie plates.
4. Remove the spring eye bolts and remove the spring and place on a suitable work surface.
5. If the spring eye bushings are to be replaced, drive out the old bushing using a suitable drift punch.

CAUTION

Be sure to wear safety glasses when removing or installing force fitted parts. Failure to comply may result in serious injury.

6. Drive the new bushing into the spring eye using a piloted drift punch or a close fitting bolt inserted through the bushing.
7. Reinstall repaired or replaced components in reverse order.

Note: For multiple axle units, the weight of each axle must be supported as outlined in Step 2 before disassembly of any component of the suspension system.

If the equalizer or equalizer bushings must be replaced, follow the instructions above for lifting and supporting the trailer unit and then proceed as follows:

1. With both axles blocked up, remove the spring eye bolt, shackle bolt, and equalizer bolt from the equalizer to be repaired or replaced.
2. Take the equalizer to suitable work surface and remove the worn bushings using a suitable drift punch.
3. Drive the new bushings into place using a piloted drift punch or a close fitting bolt through the bushing.
4. Reassemble in reverse order.



CAUTION

Be sure to wear safety glasses when removing or installing force fitted parts. Failure to comply may result in serious injury.

All of the pivot points on your standard suspension system have been fitted with anti-friction bearing materials which do not require routine lubrication. When otherwise servicing the unit, these pivot points may be lubricated if you so desire. If your trailer has been fitted with the Heavy Duty Attaching Parts Kit, you should lubricate periodically to ensure long component life.

Torflex® Suspension

The Torflex® suspension system is a torsion arm type suspension which is completely self contained within the axle tube. It attaches directly to the trailer frame using brackets which are an integral part of the axle assembly. The Torflex® axle provides improved suspension characteristics relative to leaf spring axles through the unique arrangement of a steel torsion bar surrounded by four natural rubber cords encased in the main structural member of the axle beam.

The wheel/hub spindle is attached to a lever, called the torsion arm, which is fastened to the rubber encased bar. As load is applied, the bar rotates causing a rolling/compressive

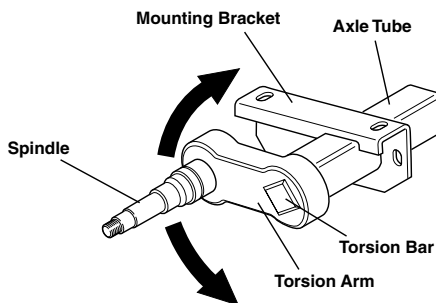

resistance in the rubber cords. This action provides the same functions as conventional sprung axles with several operating advantages including independent suspension.

Except for periodic inspection of the fasteners used to attach the Torflex® axle to the vehicle frame, no other suspension maintenance is required on Torflex® axles. They are, of course, subject to the maintenance and inspection procedures regarding brakes, hubs, bearings, seals, wheels, and tires as outlined in this manual.

CAUTION

DO NOT WELD ON THE TORFLEX® BEAM. It has rubber cords inside and the heat generated by welding could damage the cords.

Airflex® Suspension

The Dexter Airflex® suspension is a unique combination of Torflex® axle and conventional air suspension technology. This low maintenance suspension system carries the load on a cushion of air, usually supplied by an on-board compressor and storage tank. A load leveling valve maintains a constant ride height, regardless of load. As load is added to the trailer, the valve will automatically signal the compressor to supply more air. As loads are removed, the same valve will exhaust air to maintain the same height and ride characteristics.

The Airflex® suspension air generation kit has a built in dump valve which allows the trailer to be lowered several inches to facilitate loading or leveling. Once loaded, the valve is reversed and the system is pressurized to raise the trailer back up to normal running height.

Axle Adjustment

1. Support the trailer frame on a level surface. If the wheels are already mounted, make sure they are clear of the ground. If the air actuation system has been installed, make sure the air pressure in the air bags is bled off before lifting the trailer.

Note: Lifting the trailer with air system pressurized will overextend the air bags and can result in damage to the air bags.



CAUTION

Do not lift or support the trailer on any part of the axle or suspension system. Never go under any trailer unless it is properly supported on jack stands which have been rated for the load. Improperly supported vehicles can fall unexpectedly and cause serious injury or death.

2. Measure from king pin to spindle center on each side. To simplify this process, plumb lines may be dropped from the king pin and from the center line of each spindle end. Measurements "A" and "B" can then be taped on the floor to eliminate any miss measurement due to sagging of the tape for long measurements. Compare A and B measurements (see Figure 1).
3. Suspension front pivot connection is torqued to **270 Ft. Lbs.** when the suspension is shipped. The axle should be aligned on the trailer in this condition.

Wheels

Wheel Selection

Wheels are a very important and critical component of your running gear system. When specifying or replacing your trailer wheels it is important that the wheels, tires, and axle are properly matched. The following characteristics are extremely important and should be thoroughly checked when replacement wheels are considered.

1. **Bolt Circle.** Many bolt circle dimensions are available. Some vary by so little that it might be possible to attach an improper wheel that does not match the axle hub. Be sure to match your wheel to the axle hub.
2. **Capacity.** Make sure that the wheels have enough load carrying capacity and pressure rating to match the maximum load of the tire and trailer.
3. **Offset.** This refers to the relationship of the center line of the tire to the hub face of the axle. Care should be taken to match any replacement wheel with the same offset wheel as originally equipped. Failure to match offset can result in reducing the load carrying capacity of your axle.
4. **Rim Contour.**



CAUTION

Replacement tires must meet the same specifications as the originals. Mismatched tires and rims may come apart with explosive force and cause personal injury to yourself or others. Mismatched tires and rims can also blow out and cause you to lose control and have an accident which can result in serious injury or death.

 **CAUTION**

Do not attempt to repair or modify a damaged wheel. Even minor modifications can cause a dangerous failure of the wheel and result in personal injury or death.

Torque Requirements

In June of 2004, Dexter ceased production of trailer wheels. If your vehicle is equipped with Dexter steel wheels manufactured before that date, the following wheel torque information will be applicable.

If your trailer is equipped with wheels produced by other manufacturers, you must consult with the vehicle manufacturer to determine the appropriate torque level for your wheels. However, you must not exceed the limits of the wheel mounting studs on the axles.

It is extremely important to apply and maintain proper wheel mounting torque on your trailer axle. Torque is a measure of the amount of tightening applied to a fastener (nut or bolt) and is expressed as length force. For example, a force of 90 pounds applied at the end of a wrench one foot long will yield **90 Ft. Lbs.** of torque. Torque wrenches are the best method to assure the proper amount of torque is being applied to a fastener.

 **CAUTION**

Wheel nuts or bolts must be tightened and maintained at the proper torque levels to prevent loose wheels, broken studs, and possible dangerous separation of wheels from your axle, which can lead to an accident, personal injuries or death.

Be sure to use only the fasteners matched to the cone angle of your wheel (usually 60° or 90°). The proper procedure for attaching your wheels is as follows:

1. Start all bolts or nuts by hand to prevent cross threading.
2. Tighten bolts or nuts in the sequence shown for Wheel Torque Requirements.

3. The tightening of the fasteners should be done in stages. Following the recommended sequence, tighten fasteners per wheel torque requirements diagram.
4. Wheel nuts/bolts should be torqued before first road use and after each wheel removal. Check and re-torque after the first 10 miles, 25 miles, and again at 50 miles. Check periodically thereafter.

Wheel Torque Requirements

Wheel Installation Torque Sequence (Ft. Lbs.)

Wheel Size	Stud Size	1st Stage	2nd Stage	Final Torque	Cone Nut Degree
12" - 440 BC	1/2"-20	20-25	35-40	60-75	60° Cone Nut
12" - 545 BC	1/2"-20	20-25	35-40	60-75	60° Cone Nut
13" - 440 BC	1/2"-20	20-25	35-40	60-75	60° Cone Nut
13" - 545 BC	1/2"-20	20-25	35-40	60-75	60° Cone Nut
14" - 545 BC	1/2"-20	20-25	50-60	100-120	60° Cone Nut
15" - 545 BC	1/2"-20	20-25	50-60	100-120	60° Cone Nut
15" - 655 BC	1/2"-20	20-25	50-60	100-120	60° Cone Nut
16" - 655 BC	1/2"-20	20-25	50-60	100-120	60° Cone Nut
16" - 865 BC	9/16"-18	20-25	50-60	140-170	60° Cone Nut
16.5" - 655 BC	1/2"-20	20-25	50-60	100-120	60° Cone Nut
16.5" - 865 BC	9/16"-18	20-25	50-60	140-170	60° Cone Nut
16.5" x 9.75" 865 BC	5/8"-18	50-60	120-125	175-225	Special Stud Piloted With 90° Cone Nuts
17.5" Hub Pilot 865 BC	5/8"-18	50-60	100-120	190-210	Hub Piloted With Clamp Ring, 90° Cone Nuts & Greased Threads
17.5" Hub Pilot 865 BC	5/8"-18	50-60	90-200	275-325	Hub Piloted With Flange Nut
17.5" Hub Pilot 865 BC	5/8"-18	50-60	60-110	150-175	Hub Piloted With Swivel Flange Nut

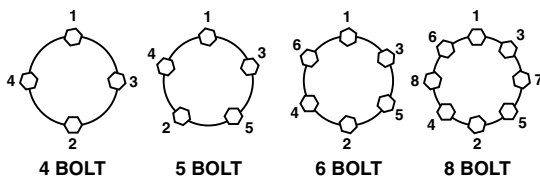

Maximum Wheel Fastener Torque

The wheel mounting studs used on Dexter axles conform to the SAE standards for grade 8. The maximum torque level that can be safely applied to these studs is listed in the following chart:

Stud Size	Maximum Torque
1/2"-20 UNF, class 2A	120 Ft. Lbs.
9/16"-18 UNF, class 2A	170 Ft. Lbs.
5/8"-18 UNF, class 2A	325 Ft. Lbs.

⚠ CAUTION

Exceeding the above listed torque limits can damage studs and/or nuts and lead to eventual fractures and dangerous wheel separation.

CAUTION

Dexter's patented Torq-N-Go™ swiveling wheel nut generates significantly more clamp load than standard wheel nuts. Do not exceed the specified torque or the wheel and/or stud may be damaged. Special caution should be observed with steel wheels. Some steel center discs may not be able to withstand the Torq-N-Go™ wheel nuts' specified operating torque. It is the responsibility of the trailer manufacturer to assure that its' wheels are compatible with this wheel nut.

Tires

Before mounting tires onto the wheels, make certain that the rim size and contour is approved for the tire as shown in the Tire and Rim Association Yearbook or the tire manufacturers catalog. Also make sure the tire will carry the rated load. If the load is not equal on all tires due to trailer weight distribution, use the tire rated for the heaviest wheel position.

Note: The capacity rating molded into the sidewall of the tire is not always the proper rating for the tire if used in a trailer application. Use the following guidelines:

1. LT and ST tires. Use the capacity rating molded into the tire.
2. Passenger Car Tires. Use the capacity rating molded into the tire sidewall **divided by 1.10** for trailer use.







Use tire mounting procedures as outlined by the Rubber Manufacturer's Association or the tire manufacturers.

Tire inflation pressure is the most important factor in tire life. Inflation pressure should be as recommended by the manufacturer for the load. Pressure should be checked cold before operation. Do not bleed air from tires when they are hot. Check inflation pressure weekly during use to ensure the maximum tire life and tread wear. The following tire wear diagnostic chart will help you pinpoint the causes and solutions of tire wear problems.

CAUTION

Proper matching of the tire/wheel combination is essential to proper function of your trailer running gear. Some tires may call for a maximum inflation pressure above the rim or wheel capacity. DO NOT EXCEED MAXIMUM INFLATION PRESSURES FOR RIMS OR WHEELS. Catastrophic failure may result.

Tire Wear Diagnostic Chart

	Wear Pattern	Cause	Action
	Center Wear	Over Inflation	Adjust pressure to particular load per tire catalog
	Edge Wear	Under Inflation	Adjust pressure to particular load per tire catalog
	Side Wear	Loss of camber or overloading	Make sure load doesn't exceed axle rating. Align at alignment shop
	Toe Wear	Incorrect toe-in	Align at alignment shop
	Cupping	Out-of-balance	Check bearing adjustment and balance tires
	Flat Spots	Wheel lockup & tire skidding	Avoid sudden stops when possible and adjust brakes

CAUTION

Tire wear should be checked frequently. Once a wear pattern becomes firmly established in a tire it is difficult to stop, even if the underlying cause is corrected.



Replacement Parts/Kits

Electric Brake Magnets

Brake Size	Magnet Kit Number (one magnet per kit)	Wire Color	Nut Torque (Ft. Lbs.) Brake Mounting
7" x 1 1/4"	K71-057-00	White	45-70
10" x 1 1/2"	K71-104-00	Green	45-70
10" x 2 1/4"	K71-104-00	Green	45-70
10" x 2 1/4"	K71-125-00 (4.4K)	Black	45-70
12" x 2"	K71-105-00	White	25-50
12" x 2"	K71-125-00 (7K)	Black	25-50
12 1/4" x 2 1/2"	K71-378-00 (7.2K)	Red/Black	55-80
12 1/4" x 3 3/8"	K71-378-00	Red/Black	55-80

Seal Replacement Reference

Brake Size	Hub Size	Standard	Seal Part No. E-Z Lube®	Oil
7" x 1 1/4"	4 or 5 Bolt	K71-301-00	K71-301-00	N/A
10" x 1 1/2"	5 Bolt	K71-302-00	K71-302-00	N/A
10" x 2 1/4"	4, 5 or 6 Bolt	K71-303-00	K71-303-00	N/A
12" x 2"***	5 Bolt Demount; 6 or 8 Bolt	K71-305-00	K71-305-00	K71-386-00
12 1/4" x 2 1/2"	8 Bolt	K71-305-00	K71-305-00	K71-386-00
12 1/4" x 3 3/8"	8 Bolt	K71-305-00	K71-305-00	K71-386-00

** 2.12" diameter seal journal prior to 10/97

2.25" diameter seal journal after 10/97

Replacement Parts/Kits

Brake Shoe Replacement Kits

Brake Size	Shoe and Lining Replacement (1 Brake)	
	Electric	Hydraulic
7" x 1 1/4" (2.2K)	K71-045-00	N/A
7" x 1 3/4" (2.5K)	N/A	K71-466-00
10" x 1 1/2" (3.0K) Nev-R-Adjust® (3.0K)	K71-046-00 K71-701-00LH K71-702-00RH	N/A N/A
10" x 2 1/4" (3.5K) Nev-R-Adjust® (3.5K) Free Backing (3.5K) Corrosion Resistant (3.5K) 4.4K Nev-R-Adjust® (4.4K)	K71-047-00 K71-681-00LH K71-682-00RH N/A N/A K71-672-00 K71-698-00LH K71-699-00RH	K71-267-00 N/A K71-393-00 K71-423-00 N/A N/A
12" x 2" (5.2K) 6K Nev-R-Adjust® (6 & 7K) 7K Free Backing (7K) Corrosion Resistant (7K)	K71-127-00 K71-127-00 K71-675-00LH K71-676-00RH K71-127-00 N/A N/A	K71-268-00 N/A N/A K71-269-00LH K71-270-00RH K71-394-00LH K71-395-00RH K71-427-00LH K71-428-00RH
12 1/4" x 2 1/2" (7.2K) (after May of 2000) Service Parts Only (7.2K) (before May of 2000)	K71-497-00LH K71-496-00RH K71-410-00	N/A N/A
12 1/4" x 3 3/8" (8K) Corrosion Resistant (8K)	K71-499-00LH K71-498-00RH N/A	K71-165-00LH K71-166-00RH K71-437-00LH K71-438-00RH
12 1/4" x 3 3/8" (8K) (stamped backing plate before April 2000)	K71-049-00LH K71-050-00RH	K71-165-00LH K71-166-00RH
3.5K Disc (painted caliper)	N/A	K71-623-00 (1 axle set)
3.5K-6.0K Disc (zinc/aluminum caliper)	N/A	K71-157-00 (1 axle set)
6.0K Disc	N/A	K71-629-00 (1 axle set)
7.0K Disc	N/A	K71-629-00 (1 axle set)
8.0K Disc	N/A	K71-629-00 (1 axle set)

Replacement Parts/Kits



Bearing Replacement Chart

Brake Size	Hub Size	Bearings	Dexter Kit Number	Industry Part # Cup/Cone	Axle Capacity
7" x 1 1/4"	4 or 5 Bolt	Inner Outer	K71-306-00 K71-306-00	L44610/L44649 L44610/L44649	2K
10" x 1 1/2"	4 or 5 Bolt	Inner Outer	K71-307-00 K71-306-00	LM67010/LM67048 L44610/L44649	2.8K
10" x 1 1/2"	5 Bolt	Inner Outer	K71-307-00 K71-306-00	LM67010/LM67048 L44610/L44649	3K
10" x 2 1/4"	4, 5, or 6 Bolt	Inner Outer	K71-390-00 K71-306-00	L68111/L68149 L44610/L44649	3.5K 4K (10F)
10" x 2 1/4"	6 Bolt	Inner Outer	K71-390-00 K71-307-00	L68111/L68149 LM67010/LM67048	4.4K
12" x 2"	6 Bolt	Inner Outer	K71-308-00 K71-307-00	25520/25580 LM67010/LM67048	5.2K
12" x 2"	5 Bolt Demount	Inner Outer	K71-308-00 K71-309-00	25520/25580 15245/15123	7K
12" x 2"*	6 Bolt	Inner Outer	K71-308-00 K71-309-00	25520/25580 15245/15123	6K
12" x 2"	8 Bolt	Inner Outer	K71-308-00 K71-310-00	25520/25580 14276/14125A	6K, 7K
12 1/4" x 2 1/2"	8 Bolt	Inner Outer	K71-308-00 K71-405-00	25520/25580 02420/02475	7.2K
12 1/4" x 3 3/8"	8 Bolt	Inner Outer	K71-308-00 K71-415-00	25520/25580 02420/02475	8K

Replacement Parts/Kits

Storage

Storage Preparation

If your trailer is to be stored for an extended period of time or over the winter, it is important that the trailer be prepared properly.

1. Remove the emergency breakaway battery and store inside, out of the weather. Charge the battery at least every 90 days.
2. Jack up the trailer and place jack stands under the trailer frame so that the weight will be off the tires. Follow trailer manufacturer's guidelines to lift and support the unit. Never jack up or place jack stands on the axle tube or on the equalizers.



CAUTION

Do not lift or support the trailer on any part of the axle or suspension system. Never go under any trailer unless it is properly supported on jack stands which have been rated for the load. Improperly supported vehicles can fall unexpectedly and cause serious injury or death.

3. Lubricate mechanical moving parts such as the hitch, and suspension parts, that are exposed to the weather.
4. Boat trailer axles are subject to repeated immersion. Before storing, remove brake drums; clean, dry and re-lubricate moving brake components; inspect bearings - clean and re-lubricate.
5. On oil lubricated hubs, the upper part of the roller bearings are not immersed in oil and are subject to potential corrosion. For maximum bearing life, it is recommended that you revolve your wheels periodically (every 2-3 weeks) during periods of prolonged storage.

After Prolonged Storage Inspection Procedure

Before removing trailer from jack stands:

1. Remove all wheels and hubs or brake drums. Note which spindle and brake that the drum was removed from so that it can be reinstalled in the same location.
2. Inspect suspension for wear.
3. Check tightness of hanger bolt, shackle bolt, and U-bolt nuts per recommended torque values.
4. Check brake linings, brake drums and armature faces for excessive wear or scoring.
5. Check brake magnets with an ohmmeter. The magnets should check 3.2 ohms. If shorted or worn excessively, they must be replaced.
6. Lubricate all brake moving parts using a high temperature brake lubricant (LUBRIPLATE or Equivalent).

CAUTION

Do not get grease or oil on brake linings or magnet face.

7. Remove any rust from braking surface and armature surface of drums with fine emery paper or crocus cloth. Protect bearings from contamination while so doing.
8. Inspect oil or grease seals for wear or nicks. Replace if necessary.
9. Lubricate hub bearings. Refer to procedure in manual.
10. Reinstall hubs and adjust bearings per instructions in manual.
11. Mount and tighten wheels per instructions in manual.

Trip Preparation Checklist

There are a number of simple rules to follow in caring for your trailer axle assembly that can add to its life and in the case of some of these rules, you may be protecting your own life as well.

Using the following checklist before starting a trip with your trailer is highly recommended. Some of these items should be checked 2-3 weeks prior to a planned trip to allow sufficient time to perform maintenance.

1. Check your maintenance schedule and be sure you are up-to-date.
2. Check hitch. Is it showing wear? Is it properly lubricated?
3. Fasten safety chains and breakaway switch actuating chain securely. Make certain the breakaway battery is fully charged.
4. Inspect towing hookup for secure attachment.
5. Load your trailer so that approximately 10% of the trailers total weight is on the hitch. For light trailers this should be increased to 15%.
6. **Do Not Overload.** Stay within your gross vehicle rated capacity (consult your trailers identification plate).
7. Inflate tires according to manufacturer's specifications; inspect tires for cuts, excessive wear, etc.
8. Check wheel mounting nuts/bolts with a torque wrench. Torque in proper sequence, to the levels specified in this manual.
9. Make certain the brakes are synchronized and functioning properly.
10. Check tightness of hanger bolt, shackle bolt, and U-bolt nuts per torque values specified in manual.
11. Check operation of all lights.
12. Check that your trailer is towing in a level position and adjust hitch height if required.



Maintenance Schedule

Maintenance Schedule

Item	Function Required	Weekly	3 Months or 3,000 Miles	6 Months or 6,000 Miles	12 Months or 12,000 Miles
Brakes	Test that they are operational.	At Every Use			
Brake Adjustment	Adjust to proper operating clearance (not required with Nev-R-Adjust® brakes).		■		
Brake Magnets	Inspect for wear and current draw.			■	
Brake Linings	Inspect for wear or contamination.				■
Brake Controller	Check for correct amperage and modulation.			■	
Brake Cylinders	Check for leaks, sticking.				■
Brake Lines	Inspect for cracks, leaks, kinks.				■
Trailer Brake Wiring	Inspect wiring for bare spots, fray, etc.				■
Breakaway System	Check battery charge and switch operation.	At Every Use			
Hub/Drum	Inspect for abnormal wear or scoring.				■
Wheel Bearings and Cups	Inspect for corrosion or wear. Clean and repack.				■
Seals	Inspect for leakage. Replace if removed.				■
Springs	Inspect for wear, loss of arch.				■
Suspension Parts	Inspect for bending, loose fasteners and wear.			■	
Suspension Wet Bolts & Equalizers	Grease.		■		
Extreme Duty Bushings	Grease.		■		
Hangers	Inspect welds.				■
Wheel Nuts and Bolts	Tighten to specified torque values.		■		
Wheels	Inspect for cracks, dents, or distortion.			■	
Tire Inflation Pressure	Inflate tires to mfg's specifications.	■			
Tire Condition	Inspect for cuts, wear, bulging, etc.		■		

Dexter Axle Limited Warranty

What Products Are Covered

All Dexter Axle Company (“Dexter”) trailer axles, suspensions, and brake control systems manufactured on or after September 1, 2016, excluding Dexter 6000 series Manufactured Housing Axles. Additional exclusions include the following brands: UFP by Dexter, AL-KO (IAC), Titan Brakes and Actuators by Dexter, and BrakeRite by Dexter products, which are covered under separate warranties.

Limited 1 Year Warranty

As specified in Dexter’s current publication “Operation Maintenance Service Manual”, grease and oil seals FOR ALL PRODUCTS have a one (1) year limited warranty to the original purchaser from the date of first sale of the trailer incorporating such components. **Except as to grease and oil seals, the following four other warranties are available.**

Limited 2 Year Warranty

Dexter warrants to the original purchaser that its electric/hydraulic brake actuators shall be free from defects in material and workmanship for a period of two (2) years from the date of first sale of the trailer incorporating such components.

Limited 5 Year Warranty

Dexter warrants to the original purchaser that its axles, suspension systems and Genuine Replacement Parts shall be free from defects in material and workmanship for a period of five (5) years. The warranty period shall begin from the date of the original purchase of the trailer and/or Genuine Replacement Parts.

Limited 7 Year Warranty

Dexter warrants to the original purchaser that its Predator Series® electric brake controllers shall be free from defects in material and workmanship for a period of seven (7) years from the date of purchase.

Limited 10 Year Warranty

Dexter warrants to the original purchaser that the suspension components of its Torflex® axles shall be free from defects in material and workmanship for a period of ten (10) years from the date of first sale of the trailer incorporating such suspension components.

Exclusive Remedy

Dexter will, at its option, repair or replace the affected components of any defective axle, repair or replace the entire defective axle, or refund the lesser of the original purchase price and the then-current list price of the axle or components. In all cases, a reasonable time period must be allowed for warranty repairs to be completed. Allowance will only be made for installation costs specifically approved by Dexter.



What You Must Do

In order to make a claim under these warranties:

1. You must be the original purchaser of the trailer in which the sprung suspension axles or Torflex® axles or components were originally installed.
2. You must promptly notify Dexter after detection of any defect, but in any case within the applicable warranty period of such defect, and provide us with the axle or applicable component serial number and any substantiation of such defect which may include, but is not limited to, the return of part(s) that we may reasonable request.
3. The axles, suspensions and components must have been installed and maintained in accordance with good industry practice and any specific Dexter recommendations, including those specified in Dexter's current publication "Operation Maintenance Service Manual".

Exclusions

These warranties do not extend to and do not cover defects caused by:

1. The connecting of brake wiring to the trailer wiring or trailer wiring to the towing vehicle wiring.
2. The attachment of the running gear to the frame.
3. Parts not supplied by Dexter.
4. Any damage whatsoever caused by or related to any alteration of the axle including welding supplemental brackets to the axle.
5. Use of an axle on a unit other than the unit to which it was originally mounted.
6. Normal wear and tear.
7. Improper alignment.
8. Improper installation.
9. Unreasonable use (including failure to provide reasonable and necessary maintenance as specified in Dexter's current publication "Operation Maintenance Service Manual including required maintenance after "Prolonged Storage").
10. Improper torque values and torquing of wheel nuts. (The proper torquing procedure and torque values are contained in Dexter's current publication "Operation Maintenance Service Manual").
11. Cosmetic finish or corrosion.

Limitations

1. In all cases, Dexter reserves the right to fully satisfy its obligations under the Limited Warranties by refunding the lesser of the original purchase price and the then-current list price of the defective axle (or, if the axle has been discontinued, of the most nearly comparable current product).
2. Dexter reserves the right to furnish a substitute of replacement component or product in the event an axle or any component of the axle is discontinued or is otherwise unavailable.
3. These warranties are nontransferable.

General

THE FOREGOING WARRANTIES ARE EXCLUSIVE AND IN LIEU OF ALL OTHER WARRANTIES EXCEPT THAT OF TITLE, WHETHER WRITTEN, ORAL OR IMPLIED, IN FACT OR IN LAW (INCLUDING ANY WARRANTY AGAINST INFRINGEMENT OR OF MERCHANTABILITY OR FITNESS FOR A PARTICULAR PURPOSE).

These warranties give you specific legal rights, and you may also have other rights which vary from state to state.

DEXTER HEREBY EXCLUDES INCIDENTAL AND CONSEQUENTIAL DAMAGES, INCLUDING LOSS OF TIME, INCONVENIENCE, LOSS OF USE, TOWING FEES, TELEPHONE CALLS, COST OF MEALS OR LODGING, FOR ANY BREACH OF ANY EXPRESS OR IMPLIED WARRANTY.

Some states do not allow limitations on how long an implied warranty lasts, or the exclusion or limitation if incidental or consequential damages, so the above exclusion or limitation may not apply to you.

Inquiries regarding these warranties should be sent to:

Dexter Axle Company
P.O. Box 250
Elkhart, IN 46515

Note: Current publication "Operation Maintenance Service Manual" can be found at www.dexteraxle.com.



Axle Identification

In the unlikely event that you should require service assistance from Dexter, please have the lot (serial) number of the axle available when you call.

On all axles produced after April 2001, this nine digit number can be found near the center on the rear side of the axle beam. Look for the words DEXTER AXLE and the lot number will be located directly under the name. For easier identification, rubbing a piece of chalk over the number may help bring out the engraving.

Recreational Vehicle axles that have been certified for use in Canada will also bear the letters CSA.



Dexter Online Parts Store

From magnets and seals to complete brake and hub kits, Dexter offers a complete line of genuine replacement parts for your trailer. Most products are available in-stock and ready to ship within 24 hours direct to you from the factory. With dedicated customer support and quick turnaround, the Dexter Online Parts Store helps keep your trailer going.

- Hub Components
- Brake Components
- Suspension Components
- Complete Hub Kits
 - Brake Assemblies & Kits
 - Brake Controllers & Actuators



Ready for Immediate Shipment

Direct to Your Door

Visit us online at www.dexteraxle.com

Dexter Video Gallery

In keeping with our continual commitment to industry safety and the development of innovative products, please feel free to view our ongoing video gallery at www.dexteraxle.com/resources/videos or scan the following QR codes. We are confident these videos will help educate and promote the Dexter product line that you, as our customer, are investing in.



Bearing
Maintenance



E/H Actuator
Installation



Electric Brakes



E-Z FLEX®
Suspension



E-Z LUBE®
System



Genuine Brakes



Genuine
Replacement Parts



Leaf Spring
Axles



Manual Bleed
Hydraulic Disc



Medium Duty
Axles



Nev-R-Adjust®
Brakes



Power Bleed
Hydraulic Disc



Removable
Spindle



Sway Control



TORFLEX®
Suspension Axles

Notes

Notes

Notes

Genuine Dexter axles and components are available nationwide from our plant locations listed below or through our network of distributors. Check our web site for the distributor nearest you.



Dexter - Headquarters

2900 Industrial Parkway East ■ Elkhart, Indiana 46516
 Phone: 574-295-7888 ■ Fax: 574-295-8666
www.dexteraxle.com

Dexter - Pit 12

301 West Pearl Street
 Fremont, Indiana 46737
 Phone: 260-495-5100
 Fax: 260-495-1701

Dexter - Pit 13

500 South 7th Street
 Albion, Indiana 46701
 Phone: 260-636-2195
 Fax: 260-636-3030

Dexter - Pit 15

500 Southeast 27th Street
 El Reno, Oklahoma 73036
 Phone: 405-262-6700
 Fax: 405-262-9089

Dexter - Pit 21

199 Perimeter Road
 Monticello, Georgia 31064
 Phone: 706-468-6495
 Fax: 706-468-2966

Dexter - Pit 23

5600 Bucknell Drive SW
 Atlanta, Georgia 30336
 Phone: 404-477-6899
 Fax: 470-443-1715

Dexter - Pit 24

135 Sunshine Lane
 San Marcos, California 92069
 Phone: 760-744-1610
 Fax: 760-744-1616

Dexter - Pit 25

1041 Baxter Lane
 Winchester, Tennessee 37398
 Phone: 931-967-5101
 Fax: 931-967-1828

Dexter - Pit 39

902 South Division Street
 Bristol, Indiana 46507
 Phone: 574-848-4491
 Fax: 574-848-4825
www.ventline.com

Dexter - Pit 51

347 King Street West
 Ingersoll, Ontario N5C 3K6
 Phone: 519-485-2210
 Fax: 519-485-2163
www.ingersollaxles.com

Dexter - Pit 52

5885 51 Steet SE
 Calgary, Alberta T2C 3V2
 Phone: 587-323-8411
 Fax: 587-327-0129

Dexter - Pit 61

21611 Protecta Drive
 Elkhart, Indiana 46516
 Phone: 574-294-6651
 Fax: 574-295-6626

Dexter - Pit 62

301 North Kennedy Street
 Shawnee, Oklahoma 74801
 Phone: 405-273-9315
 Fax: 405-273-1054

**NO PART OF THIS CATALOG MAY BE REPRODUCED WITHOUT DEXTER'S PERMISSION.
 ALL PART NUMBERS, DIMENSIONS AND SPECIFICATIONS IN THIS CATALOG ARE SUBJECT
 TO CHANGE WITHOUT NOTICE.**



www.dexteraxle.com

2900 Industrial Parkway East • Elkhart, IN 46516

Phone: 574-295-7888 • Fax: 574-295-8666

ISO 9001:2015 Certified

